

# The Basics of Robotics

FAREED SHAKHATREH

---





**LAHDEN AMMATTIKORKEAKOULU**  
*Lahti University of Applied Sciences*

# THE BASICS OF ROBOTICS

LAHDEN  
AMMATTIKORKEAKOULU  
Tekniikan ala  
Kone- ja tuotantotekniikka  
Mekatroniikka  
Opinnäytetyö  
Syksy 2011  
Fareed Shakhathreh

Lahti University of Applied Sciences  
Machine- and production technology

SHAKHATREH, FAREED:

The basics of robotics

Mechatronics thesis, 122 pages

Autumn 2011

## ABSTRACT

**The basics of robotics** are one of the rare subjects to be handled as a whole in a due to the extreme diversity of scientific technologies it incorporates. It uses quite many fields of technology, for example; mechanical engineering, electrical engineering, computer sciences, electronics, sensors, actuators and artificial intelligent. It is a multidimensional area which takes advantage of all engineering studies that exist in our life besides a hard mathematical module application which is required to be applied. One of the biggest challenges of writing this thesis was to uncover enough material that involves robotic design.

To understand the mechanical design of a robot we need to study matrix, vectors, derivate, integral and basic physics, servo motor selection and design in addition to choose the gears and linking methods. Hydraulics and pneumatics are quite important in this field and to know how we can create communication between sensors and actuators through a programmable logic system, finally programming is the method of communication.

The aim of my thesis is to pick out the most important subjects that handle robot design. I tried to be brief and direct to the subject and tried to summarize the most important aspect in this field that was quite a big challenge in my thesis because of huge amount of different technologies that are handled.

**Any student** who will read my thesis will find it an orientation towards understanding robot design and pointing out the most important tips on this field, since it is brief and short and goes straight to the point.

Keywords: Degree of freedom, Robot, Articulated robot, Trajectory planning, Mapping

Lahden ammattikorkeakoulu  
Kone- ja tuotantotekniikka

SHAKHATREH, FAREED:

Robotics perusteet

Mekatroniikan opinnäytetyö, 122 sivua

Syksy 2011

## TIIVISTELMÄ

Robottiikan perusteet, yksi harvinaisista aiheista, jota käsitellään päättötyössä kokonaisuena sen takia, että siinä sovelletaan suuri määrä eri tieteen tekniikoita. Siinä käytetään melko monia tekniikan aloja kuten koneenrakennus, sähkötekniikka, tietojenkäsittely, elektroniikka, anturit, toimilaitteet ja keinotekoinen äly. Voimme nähdä, että se on moniulotteinen ala, joka hyödyntää kaikkia insinööriopintoja, joita elämässämme on, lisäksi vaikean matemaattisen moduulin soveltamista vaaditaan. Yksi suurimmista haasteista tämän päättötyön teossa oli löytää tarpeeksi materiaalia, mikä kattaa vain robottisuunnittelun ja keskittyä lähinnä kyseiseen alueeseen. Päättötyössäni olen yrittänyt poimia tärkeimmän aiheen, joka käsittelee robottisuunnittelua ja keskittyä lähinnä siihen suuntaan. Samaan aikaan olen yrittänyt olla lyhyt ja ytimekäs aiheessa ja yrittänyt kiteyttää tämän alan tärkeimmän näkökohdan, mikä oli melko suuri haaste päättötyössäni käsiteltävien eri tekniikoiden suuren määrän vuoksi.

Ymmärtääksemme robotin mekaanista suunnittelua meidän täytyy opiskella matriiseja, vektoreita, derivaattoja, integraaleja ja fysiikan perusteita, meidän täytyy opiskella melko hyvin servomoottorien valikoimaa ja suunnittelua, sen lisäksi valita vaihteet ja yhdistämismetodit. Hydraulikka- ja pneumatiikkatietous ovat melko tärkeitä tällä alalla, ja kuinka voimme luoda viestintää anturien ja toimilaitteiden välillä ohjelmoitavan logiikkajärjestelmän kautta, lopulta ohjelmointi on tapa viestiä.

Kuka tahansa opiskelija, joka lukee päättötyöni, se olisi hänelle kuin orientaatio robottisuunnittelun ymmärtämiseen ja se osoittaa tärkeimmät vinkit tällä alalla, koska se on lyhyt, se menee suoraan asiaan.

Avainsanat: Vapausasteita, Robot, Kiertyväniveliset robotit, Kehityskaari suunnittelu, Mapping.

1	INTRODUCTION.....	1
2	INTRODUCTION FOR ROBOTICS BASICS .....	2
2.1	Introduction.....	2
2.2	Automation .....	2
2.3	Robot applications in our lives .....	3
2.4	Types of robot .....	6
2.5	Required studies in robotics.....	8
2.6	Extrapolating from nature.....	9
2.7	Comparing robots to humans .....	9
2.8	Programming a robot by teaching method .....	9
2.9	Typical programming of an industrial robot.....	10
2.10	Accuracy and repeatability of addressable points .....	11
3	TECHNOLOGIES OF A ROBOT .....	12
3.1	Introduction.....	12
3.2	Sub systems.....	12
3.3	Transmission system (Mechanics) .....	17
3.4	Power generation and storage system.....	20
3.5	Sensors .....	20
3.6	Electronics .....	25
3.7	Algorithms and software .....	27
4	SERVO MOTOR DESIGN .....	28
4.1	Introduction.....	28
4.2	Servo motor main types .....	28
4.3	Application types in servo motor.....	31
4.4	How to define a suitable servo motor speed .....	32
4.5	Servo motor gearbox .....	32
4.6	Servo motor gearbox .....	32
4.7	Choosing a suitable gearbox .....	33
4.8	Controlling inertia.....	34
4.9	A Base servo motor example in a robot .....	36
4.10	Resolution.....	38
5	INDUSTRIAL ROBOT .....	40
5.1	Introduction.....	40
5.2	History of a robot .....	40
5.3	Main types of an industrial robot .....	41
5.4	Main robot motions .....	42
5.5	Scara robot vs articulated robot: .....	44
5.6	End effectors .....	45
6	INDUSTRIAL MANIPULATORS AND ITS KINEMATICS .....	46

6.1	Introduction.....	46
6.2	Links and joints.....	46
6.3	Degree of freedom.....	50
6.4	Types of robotic chains.....	51
6.5	Degree of freedom in opened chains.....	51
6.6	Degree of freedom in closed chains.....	51
6.7	Stewart platform.....	54
6.8	Defining work space area.....	55
6.9	How to define the inverse kinematics in 2R manipulator.....	58
6.10	How to define the inverse kinematics in 3R manipulator.....	58
7	TRAJECTORY DEFINITION.....	59
7.1	Forward position problem.....	60
7.2	Inverse position problem.....	60
7.3	Simple example with planar 2R.....	60
7.4	3R planar manipulator.....	62
7.5	Prismatic joints calculation.....	64
8	POSITION, ORIENTATION, FRAMES.....	65
8.1	Introduction.....	65
8.2	Transformation.....	69
8.3	Mapping involving general frames.....	70
8.4	Translation operators.....	72
8.5	Compound transformation.....	73
9	TRAJECTORY PLANNING IN ROBOTICS.....	74
9.1	Introduction.....	74
9.2	Required data for trajectory planning.....	74
9.3	Constraints.....	76
9.4	Subject to constraints.....	76
9.5	Cubic polynomials.....	76
9.6	Why to use cubic segment?.....	83
9.7	Common strategy 4-3-4 trajectory:.....	84
9.8	Coordinate motion.....	85
10	Attachment 1.....	88
1	TRAJECTORY PLANNING BY USING ROBOT STUDIO.....	88
1.1	Introduction.....	88
1.2	Creating new station and saving it.....	88
1.3	Moving robot joint space.....	94
1.4	Target teach method.....	97
1.5	Create program using virtual flex pendant.....	102

# 1 INTRODUCTION

Many of us are wondering how a robot functions, what types of technologies are used in a robot and why we need a robot in our life. The aim is to provide the reader with a clear, simple explanation of robotics. The information is directed towards engineering students, and engineers who are interested in a robotics.

In the beginning, you will find a general idea and the development of robot technologies, some applications of an industrial robot and a non-industrial robot. How robotics has developed in the last few decades and how it begins to play a vital role in our industrial life.

The topic of the thesis is to summarize and cover the most important areas of a robot structure and design. My target was to provide the reader with an easy, simple way by using a lot of different pictures, drawings and mathematic examples to make the subject of robotics simple to understand and easy to follow step by step from the basics until the most complicated forms. Robotics study becomes an extremely large field because it contains a huge amount of different technologies, but I have covered the most important areas.

## 2 INTRODUCTION FOR ROBOTICS BASICS

### 2.1 Introduction

This chapter explains automation system and different types of automation. Why we need robots in our life. What kind of advantages we can receive from robots by viewing robot applications and the quality that can be provided by comparison to human work.

### 2.2 Automation

**Hard automation:** This kind of automation cannot handle product design variations, mass production for example; conventional machinery, packaging, sewing and manufacturing small parts. Adjustability is possible but it can only handle specific tasks with no possibility of changing its own task. These machines can be seen in our homes (washing machines, dish washers, etc).

**Programmable Automation:** This form of automation began with the arrival of the computer. People began programming machines to do a variety of tasks. It is flexible because of a computer control, can handle variations, batch product, and product design.

**Autonomous (Independent):** Endowed with a decision making capability through the use of sensors. A robot belongs to this kind of automation and it is a combination of microprocessor and conventional automation systems which can provide a very powerful system. Its high level machinery capabilities combined with fault recognition and correction abilities provided by highly evolved computer systems. This means it can carry out work traditionally carried out by humans. Examples of existing autonomous systems are animals and human beings.

**Animals** when they see food they move toward it using sense of smell or they escape when they react against danger due to senses of fear (sensors).

**Human beings** are the highest level of autonomous systems because they think and they can change plan at any moment due to their high intelligence.

**Robots** cannot reach the same high level as humans because they are programmed to do certain tasks according to certain factors which are completely programmed by human beings, but they have no possibilities to change plan like humans or plan new things unless the programmer programs them to change the plan. Because of high development of machines, sensors, actuator, digital electronics and microprocessor technology it became possible to create a robot which is autonomous (Teijo Lahtinen, Lecture at Lahti University of Applied Sciences 2009).

### 2.3 Robot applications in our lives

**Welding** Considered as a dangerous task for a human because of toxic gases emissions.



**Picture2. 1 Welding robot examples in car factory**  
([www.robot-welding.com](http://www.robot-welding.com))

The welding job is quite difficult for a person who is required to weld two pipes from different sides and angles and to sit in a difficult position for a long time. It can be hard on ones physic and can cause health problems for the worker. The

difficulty for a human is to see all the sides of welded devices when he needs to weld around a pipe as he can only see one side of the pipe.

**Painting** has similar problems to welding due to the use of toxic chemical products. Below is an example picture 2.2 of a factory robot painting a car as it moves slowly along a conveyer.



**Picture 2.2** Painting robot examples in car factory  
(YASKAWA MOTOMAN, [www.yaskawamotoman.co.uk](http://www.yaskawamotoman.co.uk))

**Assembly operation:** When we assemble a chip we need to be very precise because of very fine wires which require very precise and accurate tasks which a human cannot handle but, on the other hand, is easy for a robot.

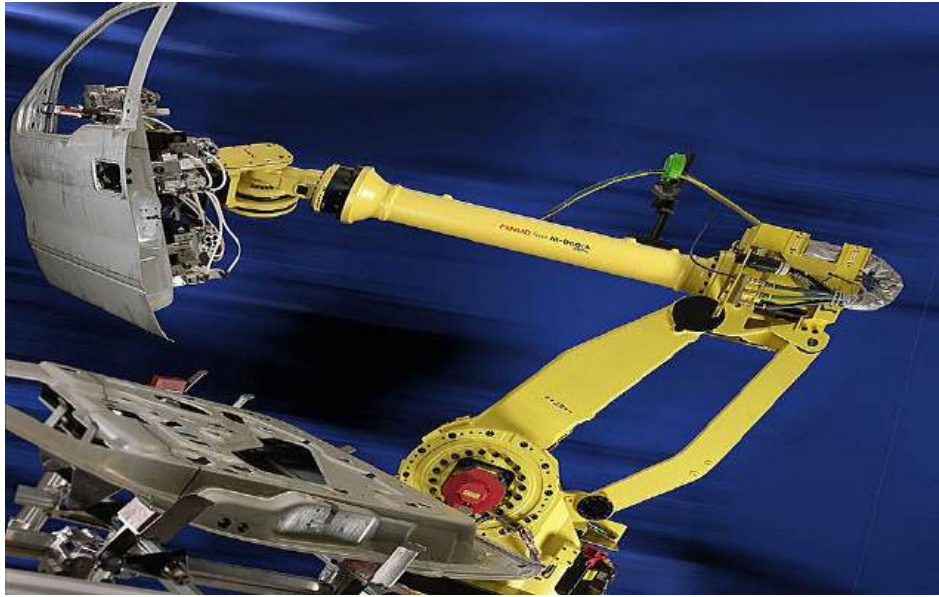

**Picture 1.3** Assembly robot examples in car factory  
(DIRECT INDUSTRY, [www.directindustry.com](http://www.directindustry.com))

**Consistent quality** at high standards can be achieved by a robot. A robot can easily be re-programmed many times to reach the highest possible quality which a human cannot often achieve.

**Safety** is especially important when a robot handles chemicals, bio chemicals, toxic and nuclear products. They can be handled very safely and smoothly, saving humans from carrying out high risk, stress inducing work.

**Robots can carefully handle fragile and tiny parts**, such as glass, small chips and wires.

**Inspection and maintenance tasks in dangerous areas:** for example handling explosives, exploring the deep sea, space and other planets. One example is the shipwrecked Titanic. A robot was used to discover the ships content as it lay so deep under the ocean it was beyond human reach.

**Space missions:** to gather samples from other planets and to analyze them from remote distances.

## 2.4 Types of robot

### 1. Industrial robots. painting and welding robots

#### Advantages of a painting robot:

Robot painting is equal, uniform with high quality and precision. It can reach very difficult places due to their high degree of flexibility which can be difficult for humans, but can be achieved easily by robots. A human needs to carry heavy painting gun and wear a mask for protection against toxic chemicals. A robot's repetition rate is high as it does not suffer from fatigue. Safety levels which can be achieved by using a robot are high by saving humans from the smell chemical toxics.

### 2. Medical robot to make surgery



**Picture2. 4** One example of a medical robot  
(LAGADIC [www.irisa.fr](http://www.irisa.fr))

#### Advantages of a medical robot:

Patient gets fast recovery. The operation is more precise with fewer mistakes. Robot can open small incisions in the body and carry out major operations with minimal damage to the patient. Therefore recovery time is decreased. The equipment is more hygienic and safe.

3. **Mobile robot with legs or wheel** for chemical power plant, under see or remote areas and bombs fields. The advantage in leg robot is that it can avoid step over obstacles which can be dangerous like bomb or even to protect objects from being destroyed due to robot moving over them.



**Picture2. 5 Leg robot picture**  
(<http://whollysblog.com/wordpress/tag/robot/>)



**Picture 2.6 Example of mobile robot**  
(<http://www.globalsecurity.org>)

4. **Robotics aircrafts and boats** without pilot which are guided from a station on the ground, which are used by army or rescue mission.



**Figure 2.7 example of a robot aircraft**  
(<http://www.wired.com/dangerroom/2008/03/pilots-yanked-o/>)

## 5. Robotic toys for entertainment



**Picture 2.8 Toy robot example**

( <http://www.questionanswers.info/2010/08/introduction-robots-types-robots-working-process-robots/>)

## 6. Robot for cleaning at home and industry



**Picture 2.9 Vacuum cleaner robot**

(<http://www.alansanchezmedia.com/robot-vacuum-cleaners.html>)

### 2.5 Required studies in robotics

It is multidimensional area which uses almost all of the engineering studies. These studies are mechanical engineering, electronic sensors, actuators, computer sciences and artificial intelligence

## **2.6 Extrapolating from nature**

As an example humans and animals have arms and fingers to manipulate objects. Legs for locomotion, muscles as actuators, eyes provide vision, nose for smelling, ears for hearing, tongue for tasting, skin for feeling and nerves for communication between the brain and actuators.

## **2.7 Comparing robots to humans**

Manipulation is equal to Arms and fingers driven by motors and other forms of actuation. Vision is equal to camera. Hearing is equal to microphone. Feeling is equal to tactile sensors. Communication is equal to wires, fiber optics and radio. Brain is equal to computers and microprocessors. Smell and taste are still under development (Matti Pitkälä, Lecture on Lahti University of Applied sciences 2011).

## **2.8 Programming a robot by teaching method**

The same technique we use to teach children to write the alphabet by holding the child's hand and going through the writing process step by step. When we are teaching the robot to do a certain job we control the movement of the robot hand or end effector at the same time we record the motion of each individual joints. Then we play back the recording and the robot begins to move independently as taught. The quality of recording results in the work carried out. This work is carried out by a skilled worker. When the work arrives on a conveyer to the robot, the robot replays the stored recording then robot performs the required task. Other ways to teach a robot to undertake certain tasks is by use of a program that creates a virtual world. Then we stimulate the work to be carried out by the robot's joint motion parameters stored in the memory. The robot is then capable of replaying the recording. (Craig 2005 340)

## 2.9 Typical programming of an industrial robot

Industrial robot is programmed by moving objects from position 1 to position 5 by moving joints vertically or horizontally to pick up and place an object through the following steps:

Define points from P1 to P5:

1. Safely move above work piece (defined as P1)
2. 10 cm above work piece (defined as P2)
3. At position to take work piece from conveyer (defined as P3)
4. 10 cm above conveyer with low speed (defined as P4)
5. At position to leave work piece (defined as P5)

Define program:

1. Move to P1
2. Move to P2
3. Move to P3
4. Close gripper
5. Move to P2
6. Move to P4
7. Move to P5
8. Open gripper
9. Move to P4
10. Move to P1 and finish

(Wikipedia [http://en.wikipedia.org/wiki/Industrial\\_robot](http://en.wikipedia.org/wiki/Industrial_robot) )

## 2.10 Accuracy and repeatability of addressable points

**Repeatability** is the playback of the recording of the position of joint space when we try to program a robot through teaching method and it describes how precise the robot to return to the stored position.

Accuracy is connected to repeatability. *“The precision with which a computed point can be attained is called the accuracy of the manipulator”* (Craig 2005, 127).

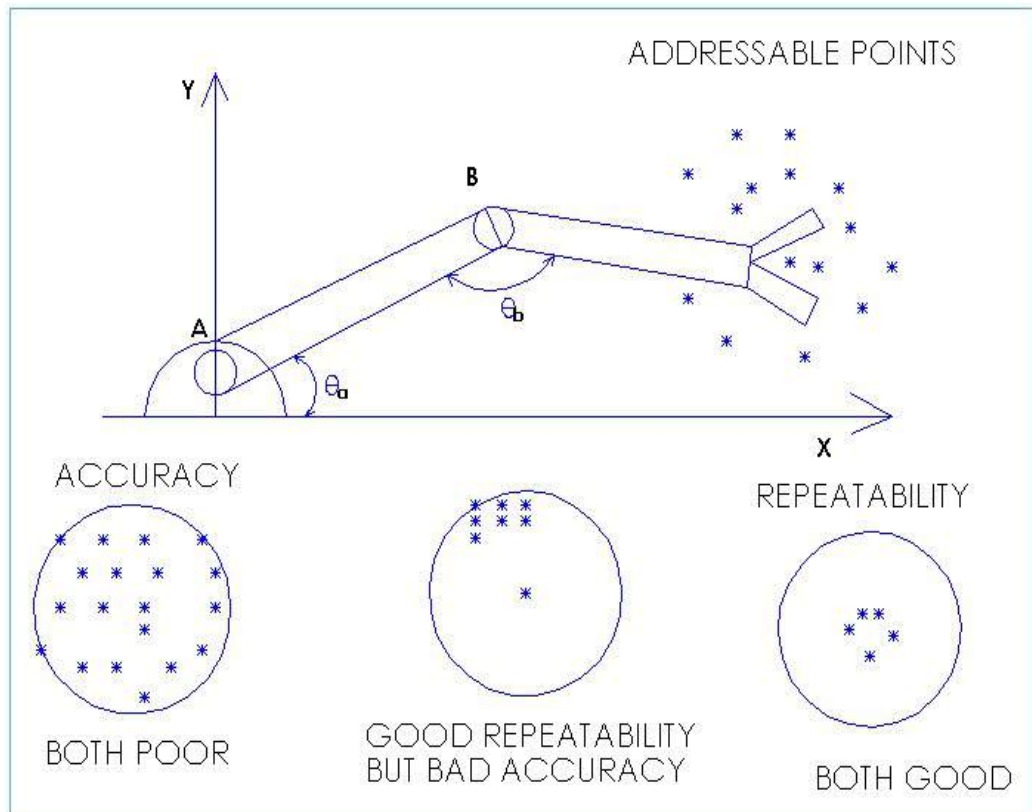

Picture 1.10 Example of good and bad accuracy

## **3 TECHNOLOGIES OF A ROBOT**

### **3.1 Introduction**

In this chapter I will introduce robot sub systems and some parts that are used in robot structure. This section will give a brief introduction to actuators, sensors, motor drive, electronics, power supplies, algorithms and software, mechanical parts and combining methods between these parts.

### **3.2 Sub systems**

Actuators and transmission systems they are solenoid, motor drive, pneumatic and hydraulic system which allows the robot to move. Mechanics parts are motors usually rotate and a mechanism to transfer motion to all the necessary parts of a robot to create the motion that is required. Usually robots require a power supply, this kind of supply depends on what a robot is required to do, and if it is a mobile robot then you need to decide the size of battery beside the efficiency since power supply will be in the board of robot, but if it is not mobile robot then electricity can be fed through a supply cable. Power storage system is battery or some other electronic devices. Sensors are two types Internal and external, there are many sensors in a robot which considered as the senses in a robot. Micro- controller and processors are the brain that controls the whole system. Algorithms and software are two models higher level and low level, programmer need to create software and algorithms to run the robot in a desired way.

## Actuators:

Actuators are essentially the prime movers providing linear force and motion.

Conventional: Pneumatics, hydraulics.



**Picture 3.1 Pneumatic valve system**  
(<http://www.stcvalve.com/>)



**Picture 3.2 Pneumatic Cylinder**  
(<http://www.industrialmuscle.co.uk/pneumatics.htm>)

### Pneumatic and hydraulic design consideration:

With this kind of system there is input and output in the cylinder, through these input and output we pump air for pneumatic system and clean filtered oil for hydraulic system to make the piston move outside and inside to provide us with linear force and motion. You need to know in robot system how far the piston should go outside or go inside, in pneumatic system we cannot control how far the piston can go outside or inside unless you put ring in the piston rod, but in hydraulic system we can control the extension of piston by controlling the oil flow through flow control valves. Pneumatic system is used when we do not need a large force to push, but hydraulics is used when a system demands a large force, especially with big machines. The problem with hydraulic system is leakage on the other hand is not a big problem in pneumatic system since it uses air. (Robert H 2006, 128-134)

**Permanent magnet motors and stepper motors** are the joint space in a robot that creates rotational motion.



**Picture 3.3**Servo motor

([http://salecnc.com/catalog/product\\_info.php?products\\_id=48&osCsid=8e3292ae10e4b2f68b41591b83e471a4](http://salecnc.com/catalog/product_info.php?products_id=48&osCsid=8e3292ae10e4b2f68b41591b83e471a4))

### **Design consideration for servo motor:**

When we design a robot, we take into consideration the torque, speed and the gearbox size which should not be so heavy to the motor drive capacity. We should pay attention to the weight of motor drives and gearboxes because the base motor drive needs to carry all the motor drives and gearboxes which require quite big torque and stronger motor in the base. The selection should be harmonic and motor should match the load. When motor rotates in a certain degree it should send feedback to the controller and to take feedback from the controller when it needs to stop rotating, this happens through an encoder which can read the degree of rotation. Nowadays these controllers are mounted in the back of the motor drive. Controller manipulates voltage and ampere to control the motor drive speed. (Teijo Lahtinen, Lecture on Lahti university of Applied Sciences 2011)

## Linear motors actuators

Are used in positioning applications where high speed and accuracy are required. Main job is to produce a linear force along its length whether up and down or left and right. It has almost the same idea like hydraulics and pneumatics cylinder but the only difference that these does not use oil or air to generate force but it uses electricity . (Paul 2003, 78).

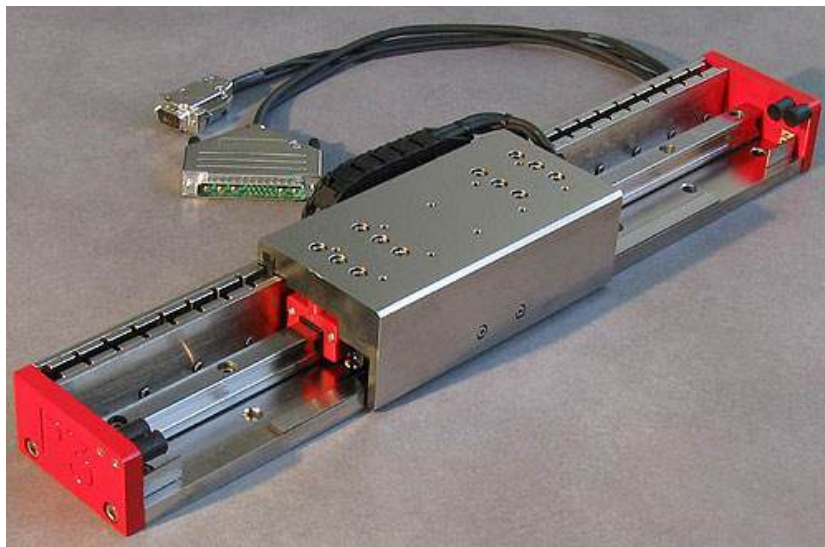

**Picture 3.4 Linear motor drive actuator**

(<http://www.designworldonline.com/articles/4087/317/Schneebergers-P3-Linear-Motor-Actuator.aspx>)

**Power supplies (PWM amplifiers):** is a device for increasing or decreasing the electrical power voltage and ampere. To be able to increase the velocity of the motor drive you need to increase the voltage and ampere through chart meter power supply amplifiers. It is very important to notice that the motor does not heat up because of high voltage or ampere.

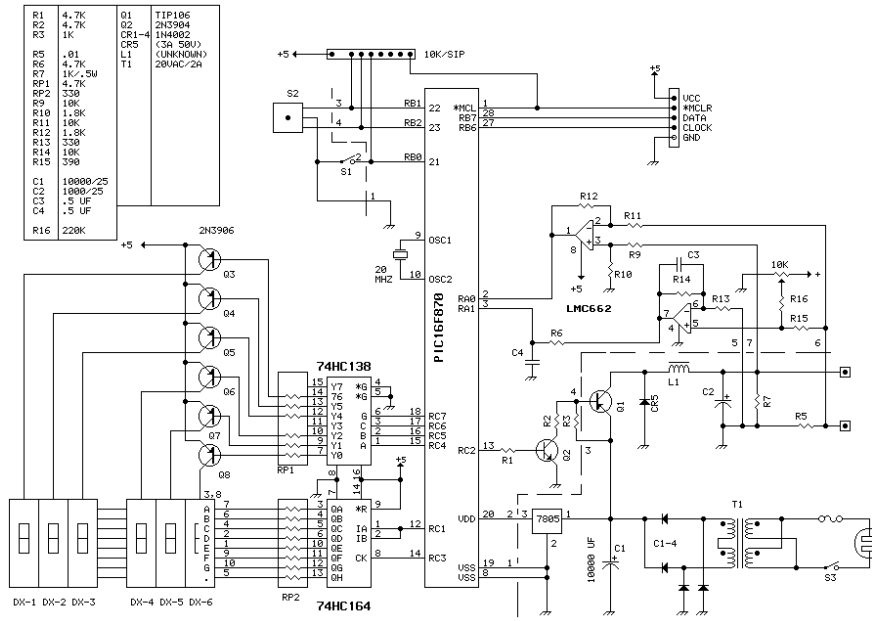

**Picture 3.5 Power supply circuit**  
(<http://www.eleccircuit.com/bench-power-supply-by-pic16f870/>)



**Picture 3.6 Power supply circuit**  
([http://www.cadaudio.dk/paindex\\_en.htm](http://www.cadaudio.dk/paindex_en.htm))

### 3.3 Transmission system (Mechanics)

1. **Gears:** the lighter the gear the better motion, less torque and higher speed. Some of this model is spur helical, bevel, worm, rack and pinion, and many others. (Paul 2003, 108).



**Picture 3.7 Gear picture**  
(<http://soheelali.blogspot.com/>)

2. **Chains:**



**Picture 2.8 Chain**  
(<http://robomatter.com/Shop-By-Product-Type/Hardware/VEX/Mechanics?page=1&sort=3a>)

3. **Timing belts:** have some kind of teeth and these teeth go around with some kind of pulley that drives this belt around it to transfer motion. It is used nowadays with robot walking machine (Paul 2003, 113).



**Picture 3.9 Timing belt with a pulley**

(<http://www.lubemobile.com.au/car-repairs/engine-components/timing-belt-or-chain.html>)

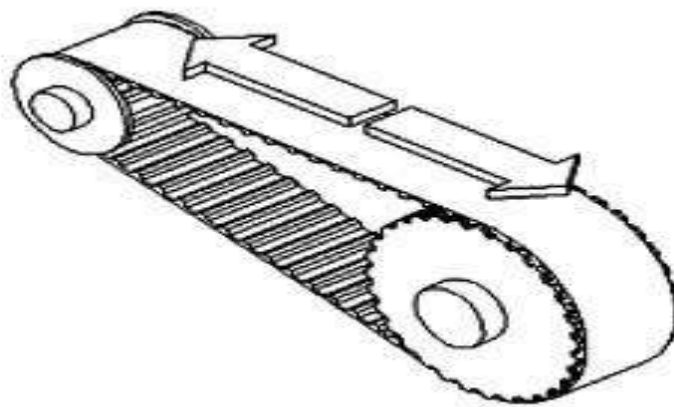

**Picture 3.10 Timing belt connected to a pulley**

([http://www.gatesmectrol.com/mectrol/brochure.cfm?brochure=5196&location\\_id=5333](http://www.gatesmectrol.com/mectrol/brochure.cfm?brochure=5196&location_id=5333))

#### 4. Metal belts, cables and pulleys



**Picture 3.11 Cables and a pulley**  
(<http://wapedia.mobi/en/Pulley>)

#### 5. Linkages:

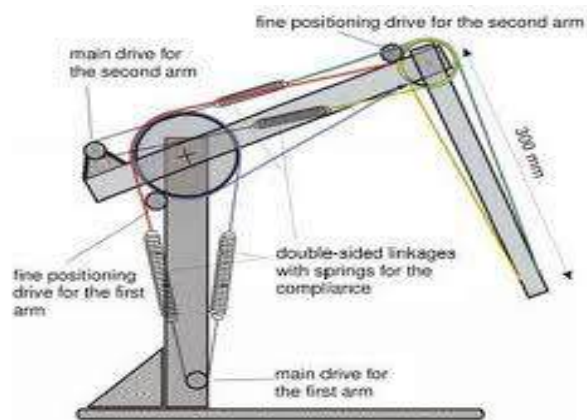

**Picture 3.12 Robot example of linkages between a servo motor and pulleys**  
(<http://www.tu-ilmenau.de/fakmb/Design-and-Applicati.4081.0.html>)

6. **Ball screws:** are very important to create linear motion backward and forward with low speed. We can use some kind of nuts, by tightening the nut we control the speed of motion.



**Picture 3.13 Ball screw**  
(<http://ballscrewservice.blogspot.com/>)

### 3.4 Power generation and storage system

Solar cells are working on the moon or in space since we need renewable energy for example sun light. Fuel cells are used in a big heavy robot so a diesel engine is required and fuel to run it, these engines power is based on hydrogen and oxygen burning. Rechargeable cells are more in use nowadays due to the technology advancements means that rechargeable cells can contain quite a lot of energy for example: batteries that are in use in mobile phones they can last long time.

### 3.5 Sensors

**Simple switch sensors are used to** turn on and off the whole cycle or some part of the cycle.



**Picture: Picture 3.14 Simple switch**  
(<http://atmac.org/simple-switch-scanning-and-voice-output-in-ms-word-2004-for-os-x>)

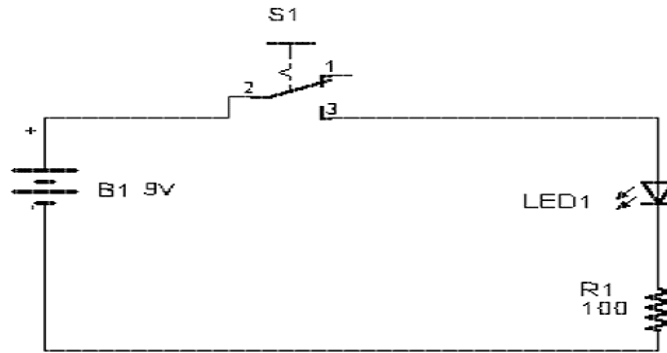

**Picture 3.15 Simple circle with simple switch**  
 (<http://www.rcgroups.com/forums/showthread.php?t=1214239>)

**Force sensor** is to measure and control the force power applied. These are mostly in use in the robot end-effectors to measure how strong the grip should be so it does not smash work pieces. They are different models with different applications for example variable force control, load and compression sensing, pumps, contact sensing, weighing and household appliances.



**Picture 3.16 Force sensor**  
 ([http://www.meas-spec.com/product/t\\_product.aspx?id=2442](http://www.meas-spec.com/product/t_product.aspx?id=2442))

**Gyroscopes:** Is a device for measuring and maintaining orientation, based on the principles of momentum. In essence, a mechanical gyroscope is a spinning wheel or disc whose axle is free to take any orientation. Although this orientation does not remain fixed, it changes in response to an external torque much less and in a different direction than it would without the large angular momentum associated with the disk's high rate of spin and moment (Wikipedia).

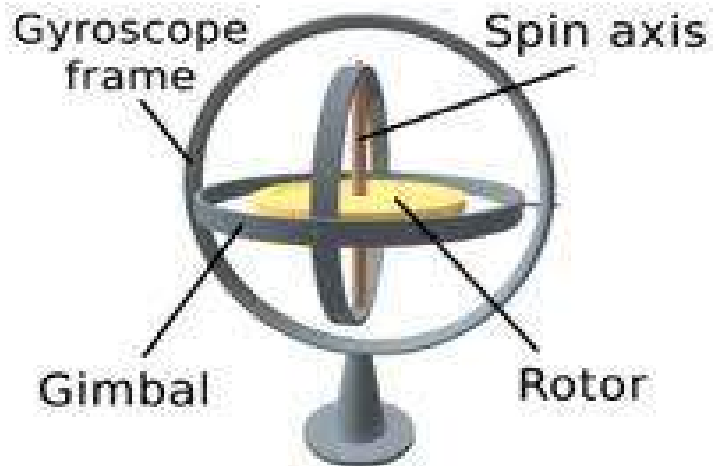

**Picture 3.17 Gyroscope**  
(<http://www.ifixit.com/Teardown/iPhone-4-Gyroscope-Teardown/3156/1>)

**Potentiometer** has the same task like encoder but uses different method for measuring degree of rotation, it convert the analogue voltage value from 0 - 10 volt to digital signal bit, which give how many degree of rotation in the motor drive. In picture 3.18 a potentiometer is mounted at the gear motor which enables the DC motor controller to measure the position of the axle.



**Picture 3.18: Servo motor with Potentiometer**  
(<http://www.wahlberg.dk/Products/Motion/Motors/tabid/166/CategoryID>)

**Digital rotary Encoder** is for measuring rotating degree of a shaft by using lines which define the degrees of rotation and to give the position of a shaft. On other way we can say the same work like potentiometer, but they are using different method for measuring degree of rotation (Paul 2003, 80).

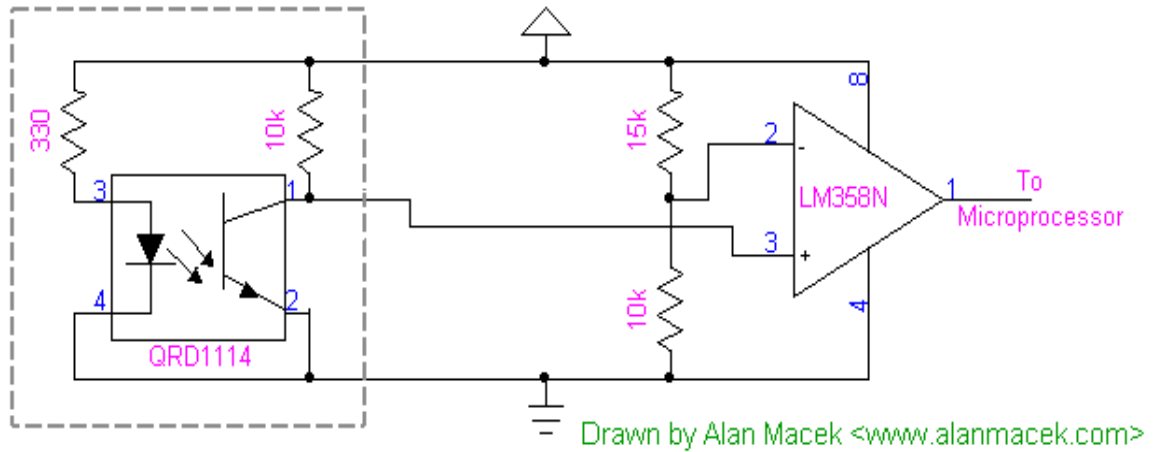

**Picture 3.19 Wheel encoder circle**  
(<http://www.alanmacek.com/robot/>)

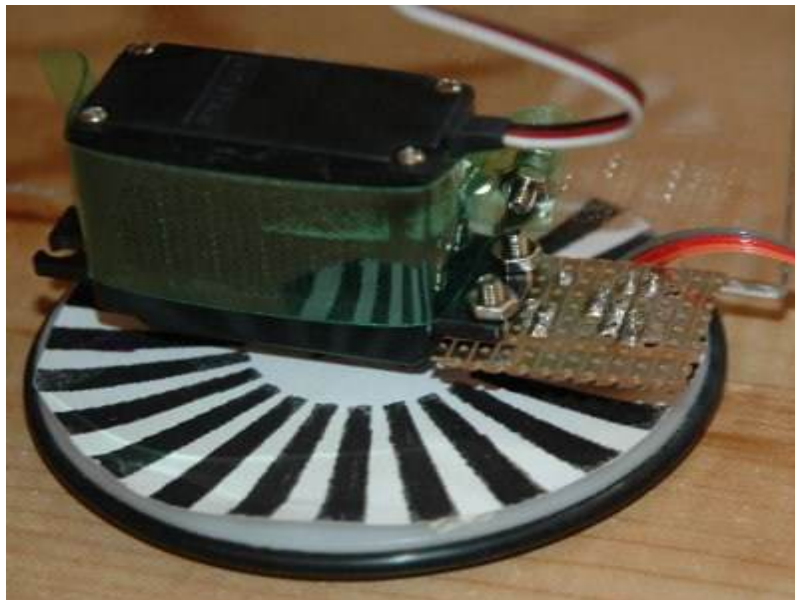

**Picture 3.20 Wheel encoder**  
(<http://www.alanmacek.com/robot/>)

**Tachometer** Essentially is a generator. Depending on the velocity of the shaft, you get certain amount of voltage output and this amount is measured by tachometer to give us visual feedback about the motor state. It is used for controlling and adjusting. Sometimes tachometer information is obtained from an encoder. (Paul 2003 88)



**Picture 3.21 Tachometer**  
(<http://www.freeclipartnow.com/transportation/cars/parts/tachometer.jpg.html>)



**Picture 3.22 Digital tachometer**  
([http://www.auberins.com/index.php?main\\_page=index&cPath=16](http://www.auberins.com/index.php?main_page=index&cPath=16))

**Cameras** are used to locate object in the robot environment. They are equal for vision system in human.



**Picture 3.23 Vision system in robot**  
(<http://www.robotshop.com/blog/robot-kits/page/2>)

**Proximity sensors:** A sensor is able to detect or recognize the presence of close objects without any physical contact with them; there are different types of these sensors which are mechanical or infrared by using light. A proximity sensor often emits an electromagnetic force or a beam of electromagnetic radiation (for instance infrared), and looks for changes in the field by reading the return signal. The object being sensed is often referred to as the proximity sensor's target. Different proximity sensor targets demand different sensors. For example, a capacitive or photoelectric sensor might be suitable for a plastic target; an inductive proximity sensor requires a metal target. (Robert H 2006, 126)



**Picture 3.24 Proximity sensor from Omron**  
([http://www.omron-ap.com/product\\_info/E2FM/index.asp](http://www.omron-ap.com/product_info/E2FM/index.asp))

### 3.6 Electronics

A to D converter and D to A converter: these converters convert analogue signal to digital signal by converting 0- 12V into single 8 byte or vice versa (Robert 2006, 46).



**Picture 3.25 DA CONVERTER**  
(<http://esoteric.teac.com/dacs/d-01/>)

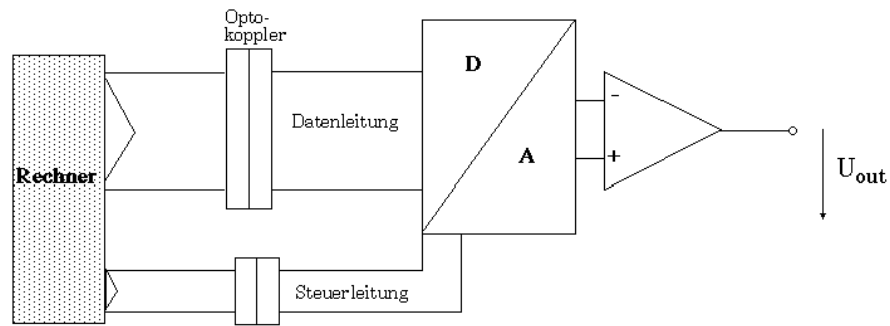

**Picture 3.26 Basic circle for converters**  
 ([http://www.fhi-berlin.mpg.de/elab/pub/Standardgeraete/DA\\_e.html](http://www.fhi-berlin.mpg.de/elab/pub/Standardgeraete/DA_e.html))

**Microcontrollers** are very small computer devices used for robot control, it contains processor core, memory, and programmable input/output peripherals (Robert 2006, 46).



**Picture 3.27 Microcontroller**  
 (<http://www.elec-intro.com/microcontroller-board>)

**Programmable logic controller** or PLC has input and output that are used to create communication between sensors and actuators. Timers are included inside PLC which can be programmed. Outputs are the actuators and inputs are the sensors. (Robert 2006, 46)

**Power Electronics** are used for running motor drive and controlling the motor speed by converting electrical power voltage and ampere to a suitable amount to produce suitable speed in the motor drive.

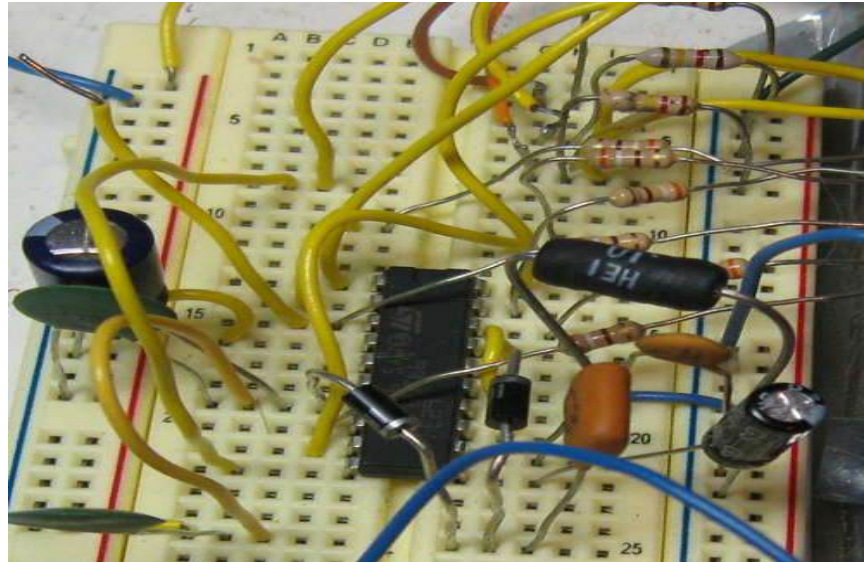

**Picture 3.28 Power electronics**  
(<http://www.instructables.com/id/BLDC-Motor-Control-with-Arduino-salvaged-HD-motor/step8/The-Power-Electronics/>)

### 3.7 Algorithms and software

Mean step by step procedure and logic programming language through logical event sequence by planning the whole task at the beginning, then controlling the motors and actuators through using feedback signal that are obtained from sensors., programmer need to plan trajectory of each individual actuator motions and to plan trajectories of end effectors. To get in the end harmonic motion with suitable speed based on logic system and task requirement.

(Robert 2006, 49-50).

## 4 SERVO MOTOR DESIGN

### 4.1 Introduction

Servo motor is the main prime mover of the robot. This section will cover the most important of servo motor types which concerns mainly robot, servo motor behavior in respect to torque, speed, current and voltage, and how to control the speed, type of application and how to choose the right servo motor with a suitable gearbox.

### 4.2 Servo motor main types

Dc servo motors are compact and light. They are two main modules permanent magnet motor (PM motors) and permanent rare earth magnets.



**Picture 4.1 Servo motor**  
(<http://electronic-machine-parts.blogspot.com/>)

The principle is similar if we talk about DC or AC motor. A conventional motor has stator magnets, rotor wound commutator and brushes. The negative side of these models is the brushes that cause electrical sparks that creates noise and electric disturbance for other surrounding electrical devices. Then by the arrival of brushless servo motor which is faster, up to 50,000 rpm. In these modules magnets are in the rotor, coil in the stator or around it, electronic circuits features the magnetic fields and the rotor motion is sensed by hall effect sensor. These models became the most usable system because it gives more reliable operation, but they are slightly more costly. (Paul 2003, 58-68).

**Performance characteristic of motor drive based on figure 4.2:**

According to the figure 4.2 there is a stall torque point, no load speed point, there is also specific voltage, which drives the motor to no load speed and stall torque. We notice that if we heavily load the motor then the speed is zero.

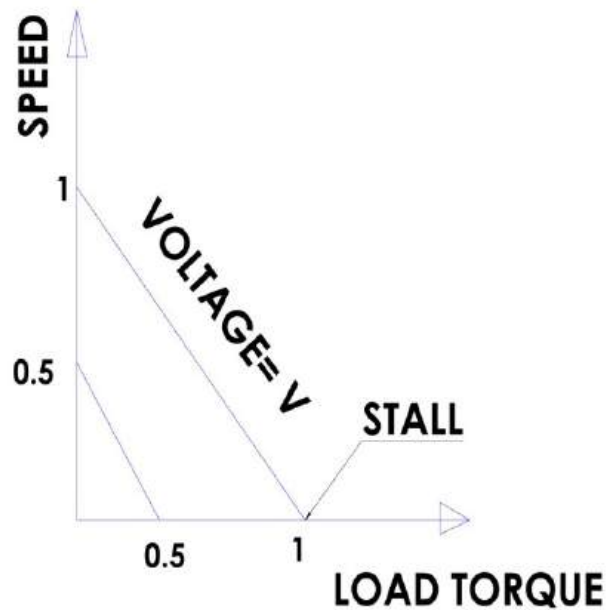

- Picture 4.2 Behavior of a servo motor with different speed and torque

**We notice from the following figure 4.3:**

There is no load current

*K<sub>t</sub>* is the motor constant value

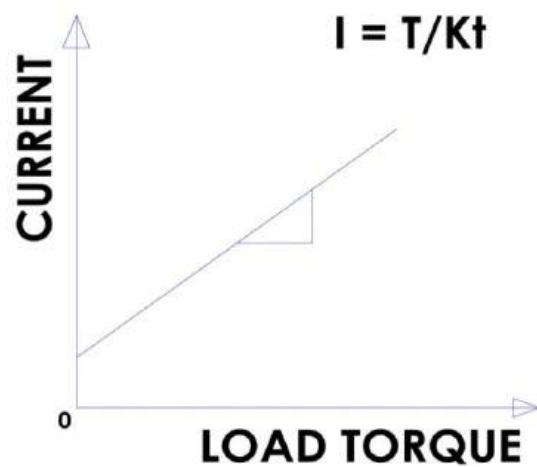

Picture 4.3 Load torque and current

**Power control of the motor:** this is how the system behaves during operation.

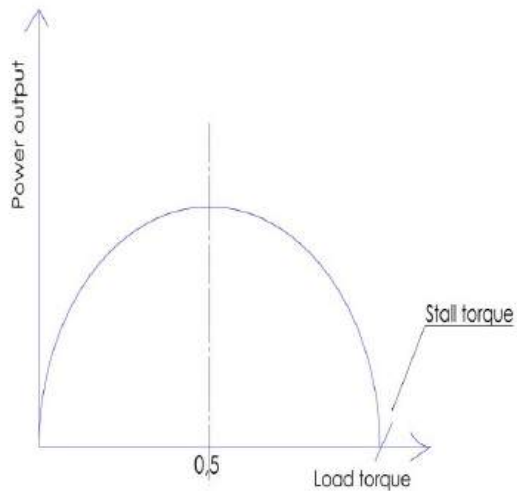

**Picture 4.4** Load torques and power output diagram

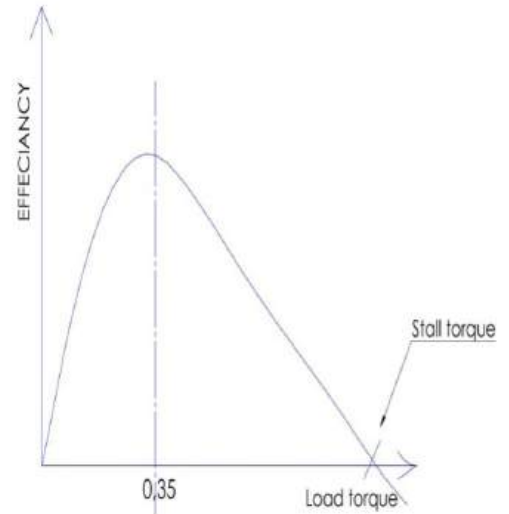

**Picture 4.5** Load torque and efficiency

### **How to select a motor in a given task:**

We need to check if the motor can supply a particular torque and speed from the manufacturer user manual catalog, if electronic amplifier is able to carry the required current, if we have enough voltage to carry the load, we need to be sure that a motor does not heat up during operation time. It is easy to predict how a motor behaves beforehand because there are several formulas and curves provided by motor manufacturers, helping us to choose a suitable motor drive.

### 4.3 Application types in servo motor

#### A. Application – continues duty operation

When we drive a certain load in a particular speed or variable speed during a period of time, we need to take into consideration the load torque, speed and if electronic circuit is able to supply the required current and voltage.

**B. Application -Intermittent operation (Intermittent motion):** that has variable speed and variable periods of time, this drawing describes the motion.

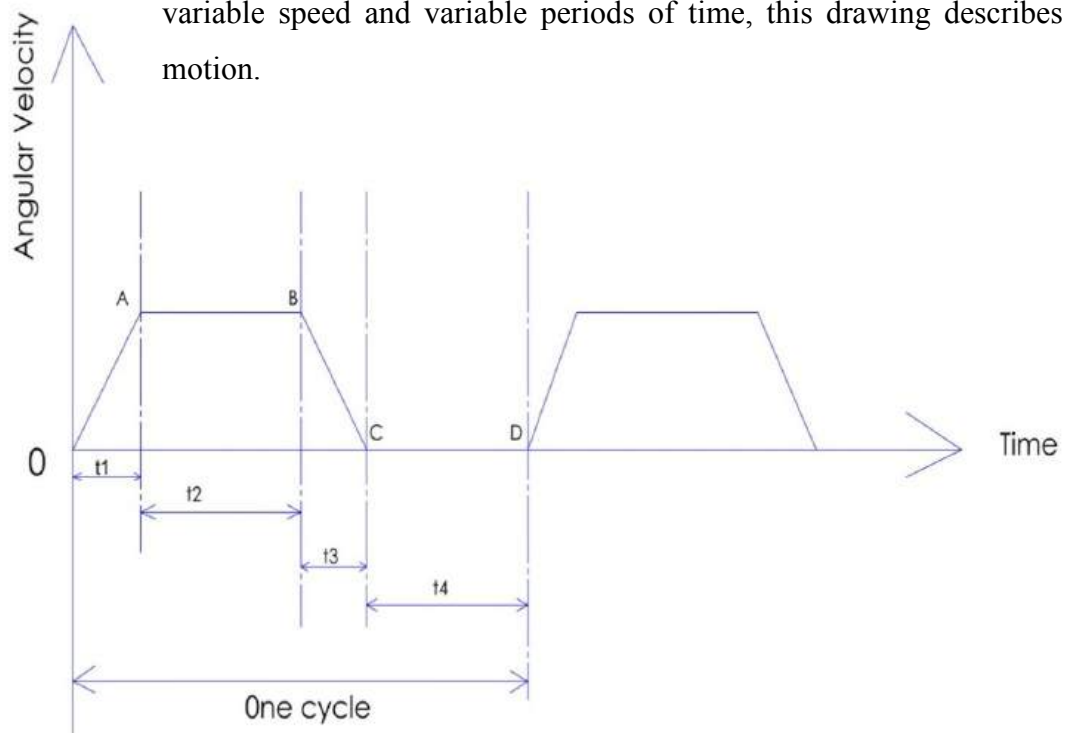

Picture 4.6 Angular velocity with relative of time

We notice from the curve 4.6 up that we have several different periods of time. From 0 to A which lasts during  $t_1$  is acceleration. From A to B which lasts during  $t_2$  is a uniform speed with 0 acceleration. From B to C which lasts during  $t_3$  is deceleration. From C to D which lasts during  $t_4$  is dwell where acceleration and velocity speed is 0.

#### **4.4 How to define a suitable servo motor speed**

We need first to calculate the speed of load, reduction ratio value by gearbox and the horse power or KW of the motor drive capacity.

#### **4.5 Servo motor gearbox**

Every motor drive has a certain load and the motor speed is quite high for example 3000 rpm or more. We need to make reduction for the speed through choosing suitable size for the gear box since the gear box has contributed for the carried load speed. If the speed is not continued at the same level, but it is variable during variable time, we need to figure out how to solve this problem.

#### **4.6 Servo motor gearbox**

Every motor drive has a certain load and the motor speed is quite high for example 3000 rpm or more. We need to make reduction for the speed through choosing suitable size for the gear box since the gear box has contributed for the carried load speed.

If the speed is not continues in the same level, but it is variable during variable time, we need to figure out how to solve this problem.

## 4.7 Choosing a suitable gearbox

**Reduction:** most of the cases we face are reductions but there are little cases of increases. We need to know the maximum speed of load (rpm) of motor drive from the guide manual which has been provided by a motor drive manufacturer.



For example maximum allowable speed for a motor is 3000 rpm and transmission ratio is 0.1.

How to calculate maximum speed of load?

$$(\text{Max speed of load}) \cdot 2 = (3000 \cdot 0,1)$$

$$\text{Maximum speed of load} = 150$$

**Conclusion:** If we know the maximum speed of load, we can base our choosing the motor drive and gear box size or vice versa on it.

$$G = \frac{\omega l}{\omega m} = \frac{\alpha l}{\alpha m}$$

G: is transmission ratio

$\alpha$  : Angular acceleration

$\omega$  : Angular speed

$l$  : Load.

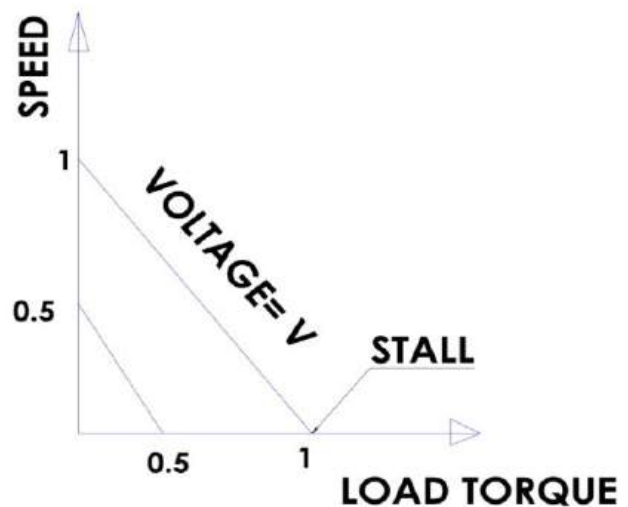

Figure 8.7 Speed and load torque diagram

Notice: The more speed, the more available torque drops, the more voltage the more speed.

## 4.8 Controlling inertia

We have to find two inertias.

- $I_m$ : motor inertia
- $I_L$ : load inertia

Torque to be provided by a motor to drive  $I_L$  is equal to

$$T_{\text{motor}} = I_L \cdot \alpha \cdot l \cdot G$$

By knowing that

$\omega$ : Angular speed

$$G = \frac{\omega l}{\omega m} = \frac{\alpha l}{\alpha m}$$

$\alpha$ : Angular acceleration

Then we satisfy the following formula by G

$$I_L \cdot \alpha_L \cdot G = I_L \cdot G \cdot \alpha_m \cdot G = G^2 \cdot I_L \cdot \alpha_m$$

$$\text{Net Torque} = I_m \cdot \alpha_m + G^2 \cdot I_L \cdot \alpha_m$$

$$\text{Effective Inertia} = I_m + G^2 \cdot I_L$$

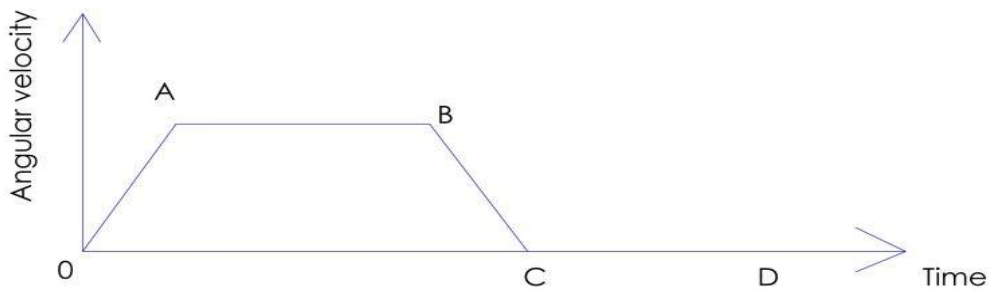

Figure 4.8 Angular velocity with respect of time

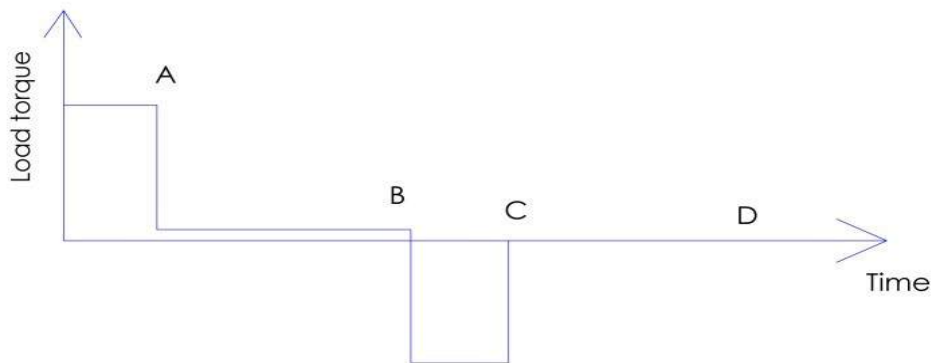

Figure 4.9 Load torque with respect of time

In figure 4.9 the sum of torque from 0 to A = to sum of torque A to B +B to C

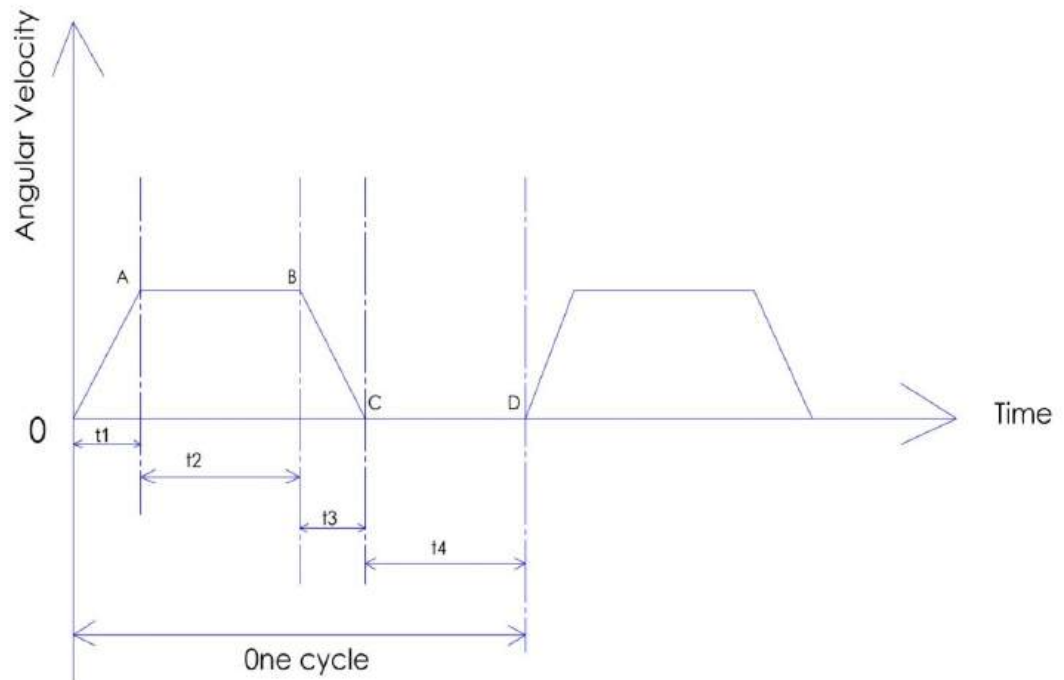

Figure 4.10 Angular velocity with respect of several period of time

From 0 to A during time  $t_1$  according to figure 4.10

$$\text{The motor angular acceleration} = \frac{\omega_a - 0}{t_1} = \propto 1$$

$$\text{Torque } T_1 = (I_m \cdot G^2 \cdot I_L) \propto 1 + T_f \cdot \frac{G}{\eta}$$

$T_f$ : torque friction

$\eta$ : Efficiency

$\omega_a$  : angular speed in A

From A to B during time  $t_2$

the angular motor acceleration = 0 (constant velocity)

$$\text{Torque } T_2 = T_f \cdot \frac{G}{\eta}$$

From B to C during time  $t_3$

$$\text{the motor angular acceleration} = \frac{\omega_b - 0}{t_3} = \propto 3$$

$$\text{Torque } T_3 = (I_m \cdot \frac{G^2}{\eta} \cdot I_L) \propto 3 - T_f \cdot \frac{G}{\eta}$$

It is minus friction because friction aids deceleration.

$$T_{RMS} = \sqrt{\frac{T_1^2 \cdot t_1 + T_2^2 \cdot t_2 + T_3^2 \cdot t_3 + (zero) \cdot t_4}{t_1 + t_2 + t_3 + t_4}}$$

Now we can select the suitable motor according to the following drawing.

$T_{PEAK}$  = the maximum value of magnitude  $T_1$ ,  $T_2$ ,  $T_3$  and  $T_4$

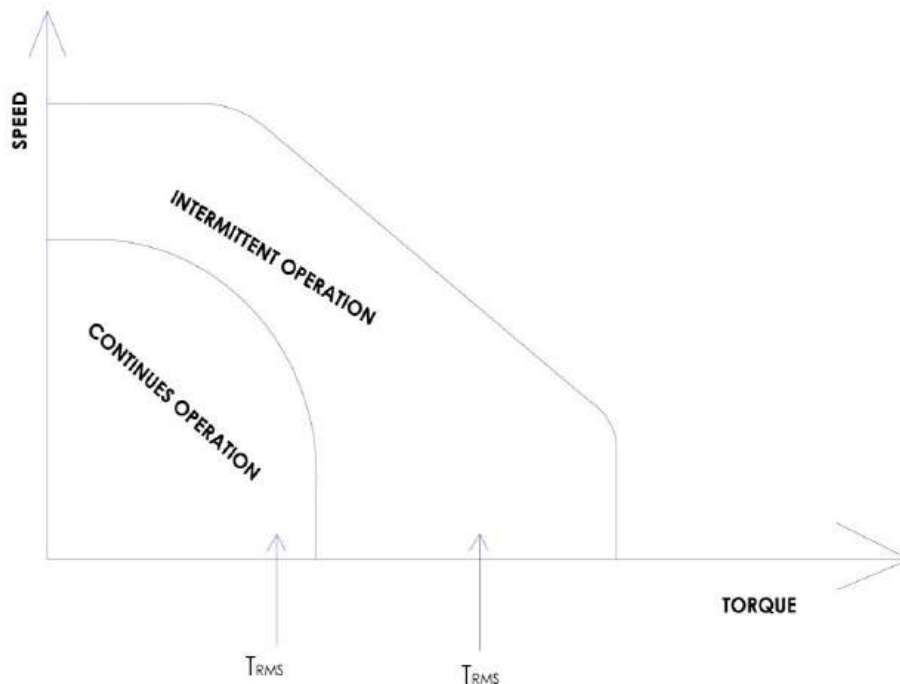

Figure 4.11 Diagram for selecting suitable motor drive

(Teijo Lahtinen, Lecture on Lahti University of Applied sciences 2011)

#### 4.9 A Base servo motor example in a robot

In the picture 4.12 an arm operation mechanism for an industrial robot includes a support, a first arm, a second arm, a link base, a parallel link and a conversion mechanism. The first arm has a base end pivotally connected to the support for rotation relative to the support. The second arm has a base end pivotally connected to a tip end of the first arm for rotation relative to the first arm. The link base is pivotally connected to the first arm for rotation relative to the first arm. The parallel link keeps a constant posture of the link base upon the rotation of the first arm. The conversion mechanism converts the rotation of the link base relative to the first arm into the rotation of the second arm relative to the link base. (Free patents online, <http://www.freepatentsonline.com/>)



## 4.10 Resolution

### The resolution of a stepper motor

Assume that we connect stepper motor on a screw with nut on the screw, then we run the motor drive forward and backward then nut begin to move with the movement of stepper motor and there is minimum distance that nut can't go below which is the limit, this some kind of example of motor drive resolution.



**Picture 4.13 Servo motor with screw ball**

([http://www.servo-drive.com/stepper\\_motors\\_linear\\_actuators\\_linear\\_stepper\\_motor.php](http://www.servo-drive.com/stepper_motors_linear_actuators_linear_stepper_motor.php))

## Servo motor drive gets feedback from an encoder or a potential meter

Resolution depends on the number of lines inside encoder, the more resolution you want the more expensive encoder and the more lines it has.

For example, encoder that has 360 lines means that it has one degree of resolution but it cannot go below one degree.



**Picture 4.14 : Optical incremental rotary encoder**

(<http://www.directindustry.com/prod/gsi-microe-systems/optical-incremental-rotary-encoders-39494-523542.html>)

**Potential meter** uses different method, which is analogue signal, which is converted to digital through electronics.

Example: let us assume potential meter signal is 10 volt which equal 8 bit then:

$$2^8 = 256 \text{ digit}$$

$$360^\circ / 256 = 1.4 \text{ Resolution per step. (Robert H 2006, 43).}$$

## 5 INDUSTRIAL ROBOT

### 5.1 Introduction

I will try to give a brief history about an industrial robot, covering different types of industrial robots and their differences especially articulated robot and scara robot and their differences, besides giving small introductory idea about the end effector and its rotational movement types.

### 5.2 History of a robot

It began in 1954 when Devol and Egelberger created the first robot and a computer was just about coming, so they built not sophisticated controller robot but they created programmable system that can do a variety of tasks. Then they established the Unimation company that manufactured these programmable systems (Wikipedia, [http://en.wikipedia.org/wiki/Industrial\\_robot](http://en.wikipedia.org/wiki/Industrial_robot)).

In 1970 in the University of Stanford they created an arm which is actuated through electrical servo motor and controlled by a computer to do variety of tasks (Wikipedia, [http://en.wikipedia.org/wiki/Industrial\\_robot](http://en.wikipedia.org/wiki/Industrial_robot)). In 1981 Japanese created Scara arm which is especially designed for product assembly. The idea of this robot is to do what human does and sony walk man was the first robot assembly (Wikipedia [http://en.wikipedia.org/wiki/SCARA\\_robot](http://en.wikipedia.org/wiki/SCARA_robot)).

The typical industrial robot which looks like a human arm has six different joints like an elbow joint, a shoulder joint and a rest joint. These joints are powered by a servo motor or a hydraulic motor or whatever type of motor. These powered motor joints enable robot to reach objects in several ways. The amount of joint space motor drive is depending on the nature of a robot task. One motions less on motor drive less. There are several types of robot with less motor drive for example 4 different joint space. The more sophisticated the job the more motions we require so extra motor drive is need. All these six motor drives need to be controlled to achieve specific task and sometimes we do not need to use all of them so we eliminate some motor joint depending on the task requirements. ([http://en.wikipedia.org/wiki/Industrial\\_robot](http://en.wikipedia.org/wiki/Industrial_robot))

### 5.3 Main types of an industrial robot

There are two main types of industrial robot the first one is called an Industrial manipulated and the second one is automated guide vehicles robot.

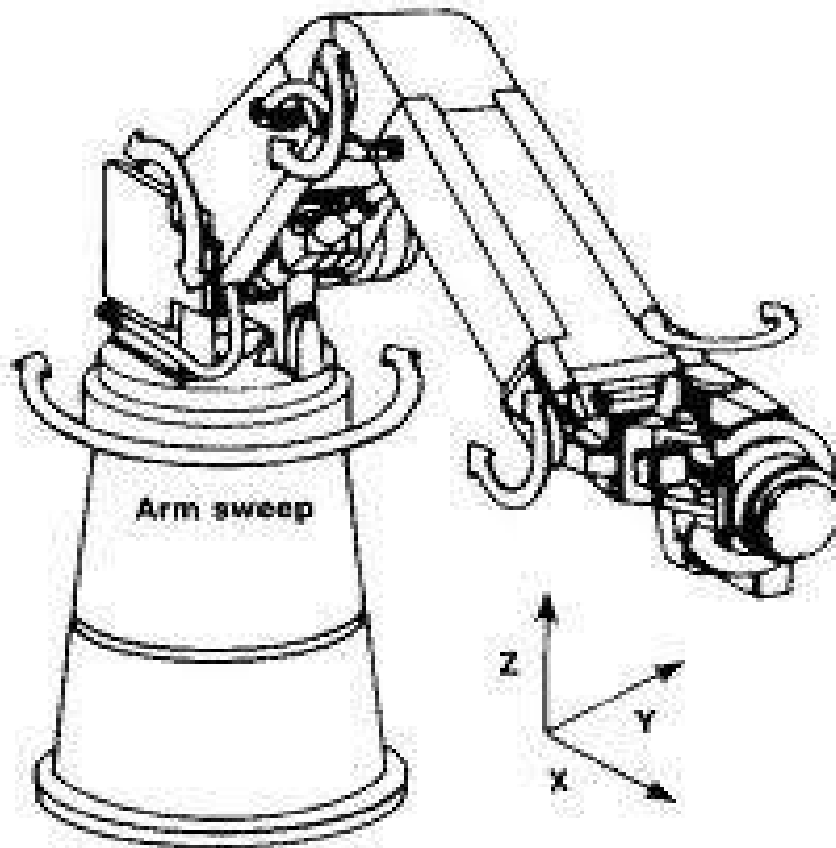

**Picture 5.1 Industrial robot**  
(<http://www.ise.ncsu.edu/kay/mhetax/PosEq/index.htm>)

For example if you think of your hand when you use it to pick up a pencil, there is rolling motion on the rest but you don't use this motion while writing, so you eliminate this motion because the axis is symmetrical. These six motor motions we called six axis which are driven independently.

## 5.4 Main robot motions

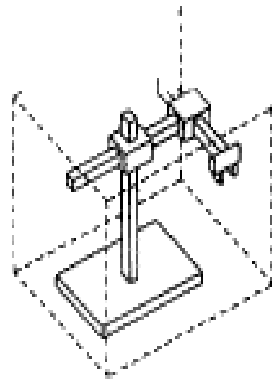

Rectangular Coordinate Robot

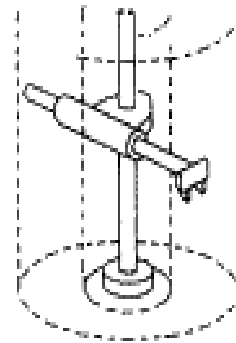

Cylindrical Coordinate Robot

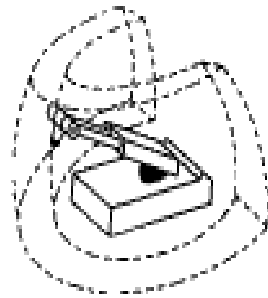

Spherical Coordinate Robot

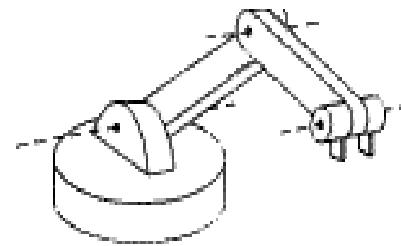

Articulated Arm Robot

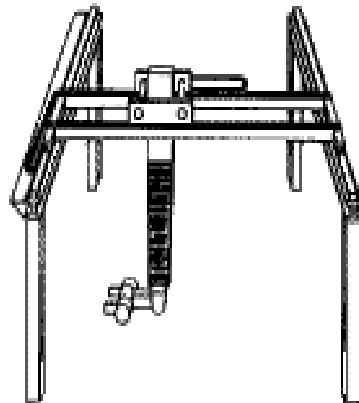

Gantry Robot

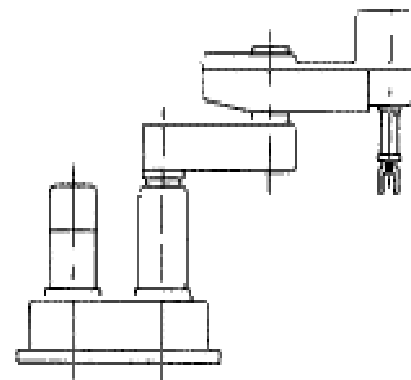

SCARA Robot

Picture 5.2 Robot types according to their motion

**Rectangular coordinate motion (Cartesian):** there are three different motions which are X, Y, Z or in other word this robot can move up and down, left and right, backward and forward, but it has no rotation or degrees. In this kind of model it is easy to control motion just by giving the coordinates, then a robot moves according to (x, y, z) values.

**Cylindrical coordinate Robot:** it has rotational movement on the base and Cartesian motion in the upper part.

**Spherical coordinate robot:** is a robot with two rotary joints and one prismatic joint.

**Articulated arm robot:** it looks like human arms base rotational like a shoulder, an elbow and a rest which give us more motion with certain angles which is not possible by Cartesian robot. This model is more complicated to control because you need to calculate angles, velocity and acceleration to get a desired motion and requires solving plenty of equation.

**Gantry robot:** is a linear motion robot and has another industrial name as a linear robot.

**Scara robot:** is created by Japanese 1979 for assembly tasks because it moves in two planes. It is simple to use in assembly operation, when you need to tight a screw and to hold it vertically then to rotate the screw and push down you don't require very big sophisticated robot, so Scara robot is the best choice for a similar operation or like pushing object down like gear box and so on.



**Picture 5.3 Scara robot**

(<http://news.thomasnet.com/fullstory/SCARA-Robot-performs-high-speed-operations-466161>)

All these models are used by engineers and every model has positive and negative sides. Depended on the job requirement we try to choose the right model to suite our requirement.

### 5.5 Scara robot vs articulated robot:

Features	Articulated robot	Scara robot
Reach	2.5 m	1.2 m
Pay load	125 kg	10 to 50 kg
Waist rotation	360 degrees	120 degrees
Rotational Speed	100 to 200 degrees/sec	tip speed 2 met/sec
Repeatability	0.4 mm	0.03 to 0.05 mm
Weight	1600 kg	30 to 100 kg

There is even more features to compare but these are the main features that can make the difference between an articulated robot and a Scara robot.

## 5.6 End effectors

Is a robot hand that grabs an object and moves it from one place to another. In the end effectors usually there are three rotational motions with three different motors and it equal human rest for lifting objects. End effector are different model with different task option.



**Picture 5.4 Robot end effector**  
(<http://en.wikipedia.org/wiki/File:Endeffector.png>)

End effectors motions are three: Rotating motion, up and down motion with angle, holding object motion.



**Picture 5.5 Robot end effector**  
(<http://jloga.edublogs.org/2009/02/10/what-are-the-5-different-parts-of-a-robot/>)

Notice: since the motor drive is heavy it would be better, if we put all the motors on the base and try to move them through linkages, cables and pulleys so we do not need to carry heavy load.

## 6 INDUSTRIAL MANIPULATORS AND ITS KINEMATICS

### 6.1 Introduction

In this section I will try to give an idea about types of links and joints and the serial chains combination, also to focus on explaining the term (degree of freedom) in an open chain and a closed chain and how to calculate it. Beside that I give several drawing examples about different types of links and chains to make the idea easy and clear to understand. In the end of this section I will define the work space area for a robot and what type of work space we have. I explain 2R and 3R manipulator work space beside the direct and inverse kinematics work space.

**First we need to define the following:**

**Serial chain** is a combination of links and joints in the space.

**Notice:** we need to understand the word degree of freedom and to know how to define how many degrees of freedom a robot has.

### 6.2 Links and joints

**Joints:**

Two different types of joints:

1. Revolute joints(R): this joint is powered by a servo motor.

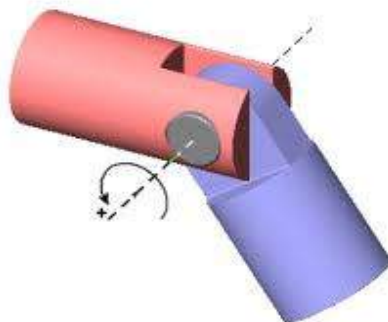

**Picture 6.1 Revolute joint**

(<http://www.mathworks.se/help/toolbox/phymod/mech/ref/revolute.html>)

Example (figure 6.2) a robot has three revolute joints so we call it (RRR) or (3R), which mean three degree of freedom with so called planar manipulator.

**Notice:** we begin to calculate (R) beginning from base to end effector.

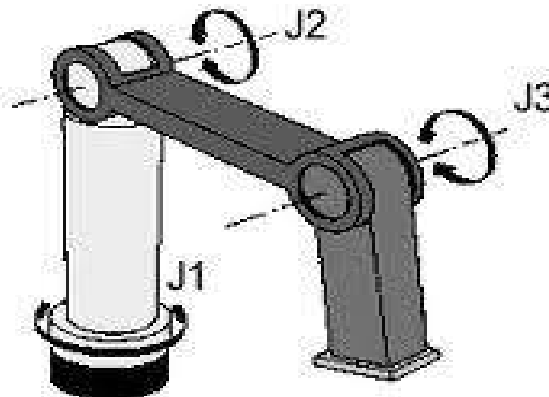

**Picture 6.2 Example of robot with 3 revolute joints**  
<http://ingenieur.kahosl.be/labos/digitaal/robots.htm>

2. Prismatic joints (P): is powered by a cylindrical piston like pneumatic system or hydraulic (example 6.3).

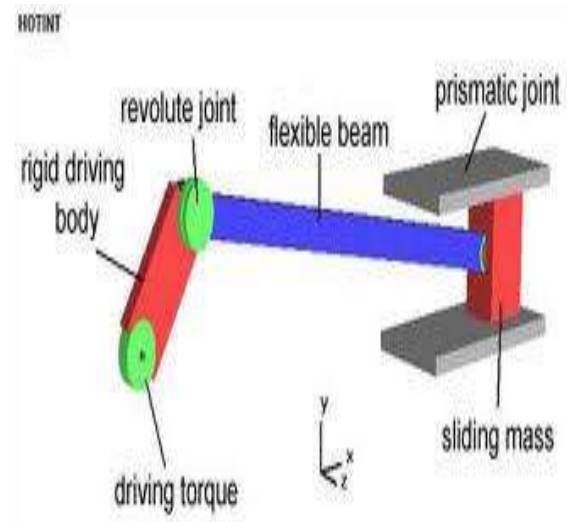
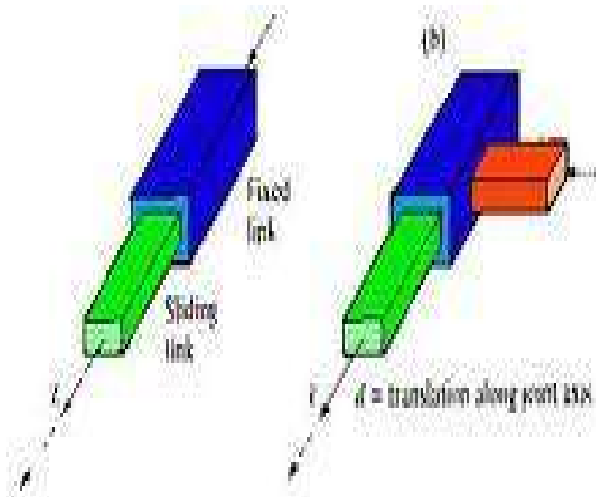

**Picture 6.3 Example of prismatic joints**  
<http://www.soton.ac.uk/~rmc1/robotics/argeometry.htm>

Example 6.5 of one prismatic and two revolute joints: we call it (RPR) with three degrees of freedom and this model can be called redundant.

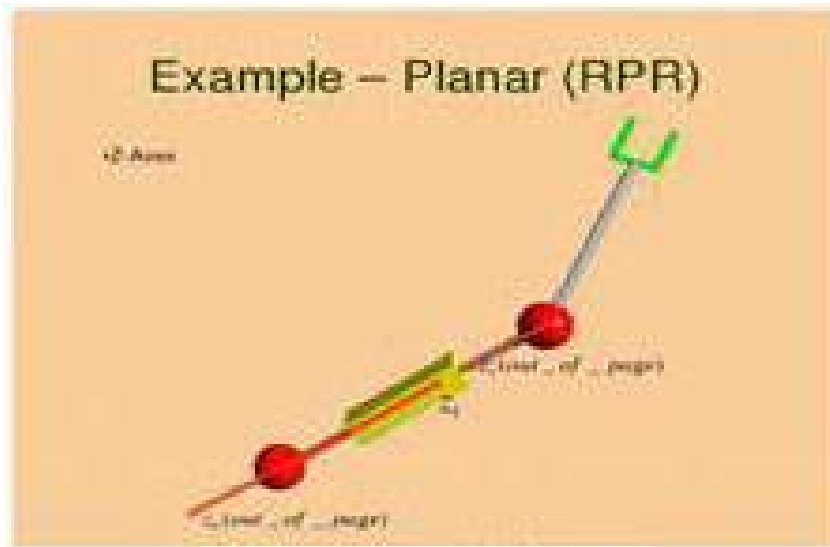

Picture 6.4 Planar RPR

More examples (6.6):

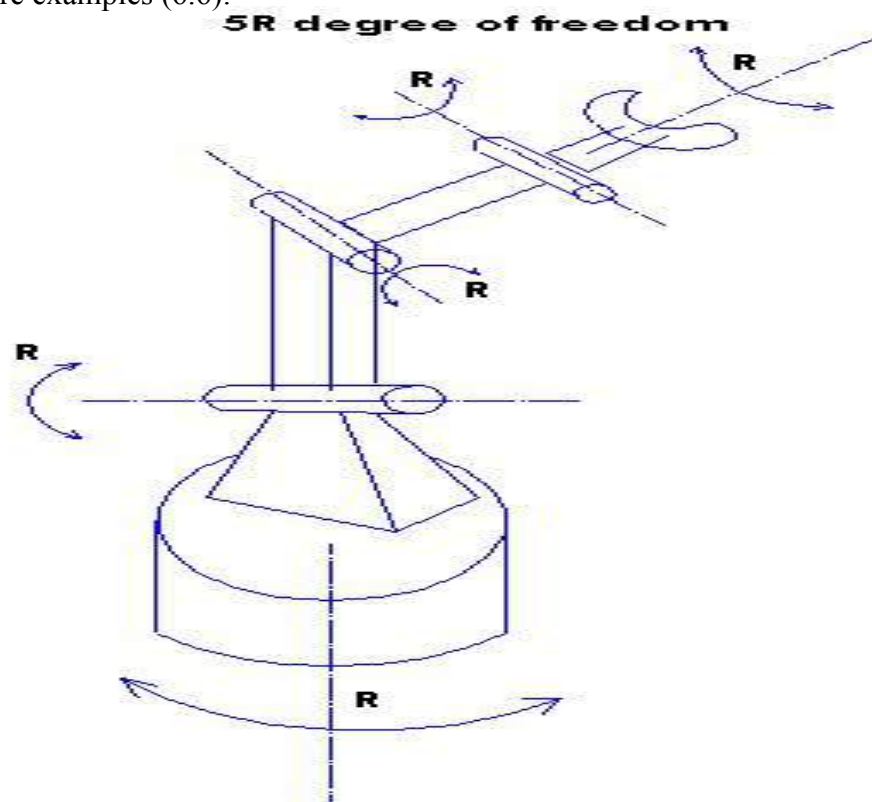

Picture 6.5 Example of a robot with five degrees of freedom

### 2RP2R DEGREE OF FREEDOM

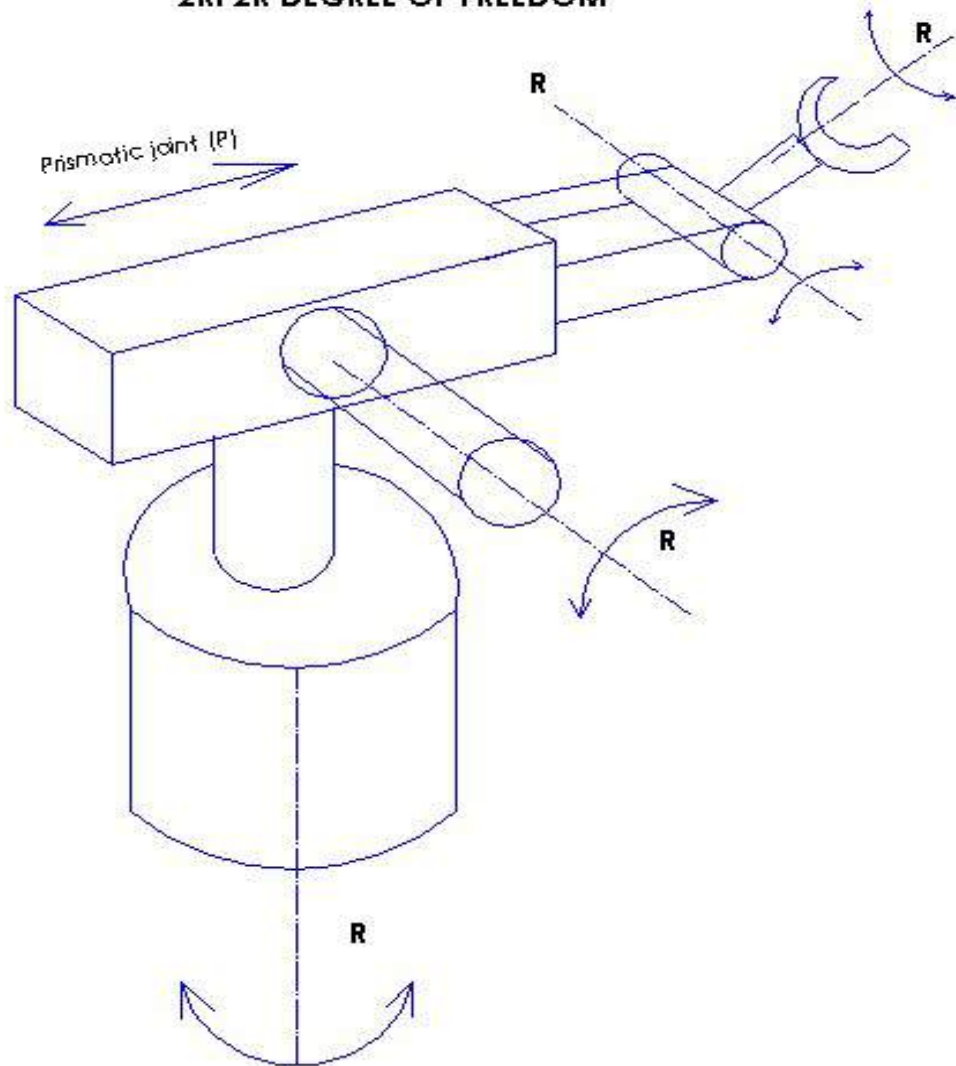

Picture 6.6 Example of a robot with 2RP2R

In this example we calculate from the base first revolute joint as R then second revolute joint as R. After that comes one prismatic joint so we have so far 2RP, then we end up with 2 revolute joint, then the total will be 2RP2R.

### 6.3 Degree of freedom

First I need to explain the term degree of freedom (DOF).

When I fix a joint and prevent any movement then I can say that this joint has zero degree of freedom but when I mount a joint with a motor drive, then it loses two degrees of freedom and it will have just one degree of freedom because it moves in one plane.

**Notice:** in the space there is six degrees of freedom.

**Spherical joints** have three degrees of freedom and it moves in three planes.



**Picture 6.7 Spherical joint**

(<http://www.shutterstock.com/pic-23189869/stock-photo-car-detail-spherical-joint.html>)

**Hooke joint** has two degrees of freedom and it move in two planes.

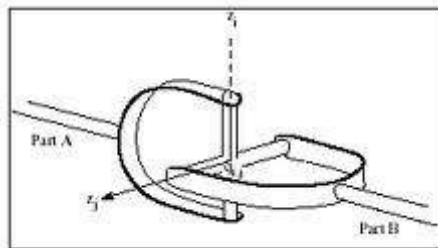

**Picture 6.8 Hooke joint**

([http://ti.mb.fh-osnabrueck.de/adamshelp/mergedProjects/solver/f\\_hlp/statements/fstate\\_joint.htm](http://ti.mb.fh-osnabrueck.de/adamshelp/mergedProjects/solver/f_hlp/statements/fstate_joint.htm))

## 6.4 Types of robotic chains

### 6.5 Degree of freedom in opened chains

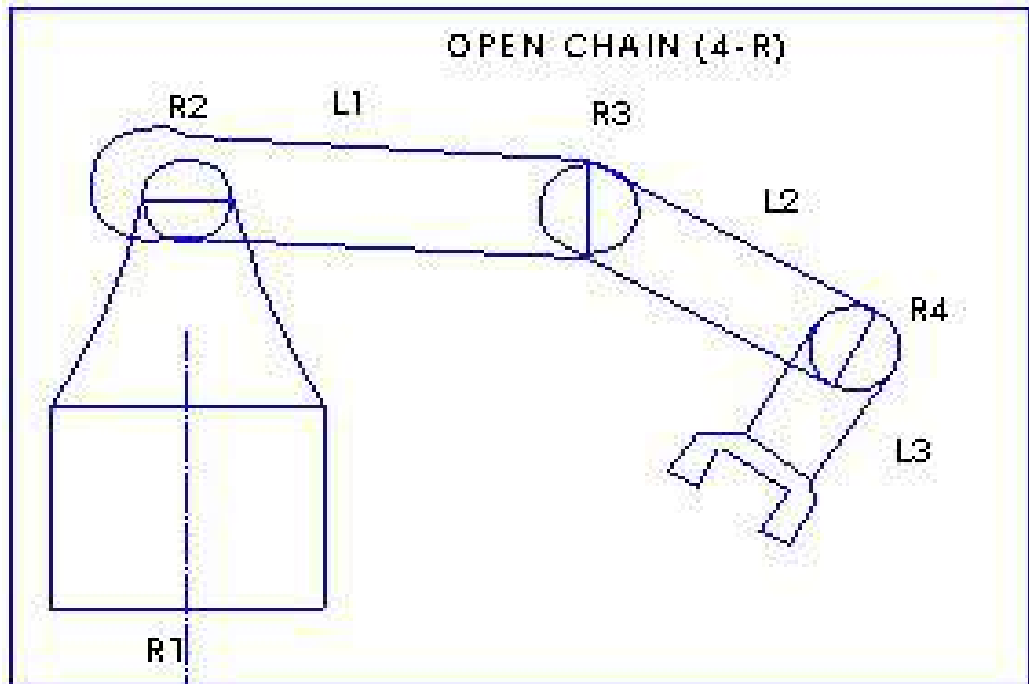

Picture 6.9 Example of four degrees of freedom in open chain

In open chains it is easy to calculate how many degrees of freedom. For a robot just by calculating the rotations axes and prismatic axes. In the example up we have four revolute joints that means we have four degrees of freedom

### 6.6 Degree of freedom in closed chains

How to calculate degree of freedom for closed chains?

We need to define how many links, revolute joints and prismatic joints.

$$\text{degree of freedom} = 3(n-1) - 2J_R - J_p$$

$J_R$ : Number of revolute joints

$J_p$ : Number of prismatic joints

n: Number of links

Example 1

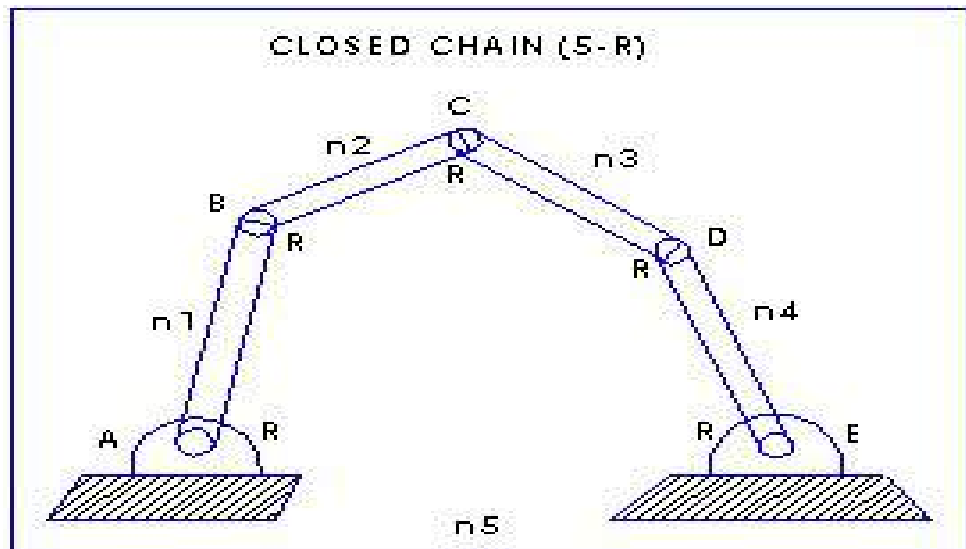

Picture 6.10 Closed chain

In the example up we calculate degree of freedom this way:

$$3(5-1)-2(5)-2(0)= 2 \text{ dof}$$

Example 2

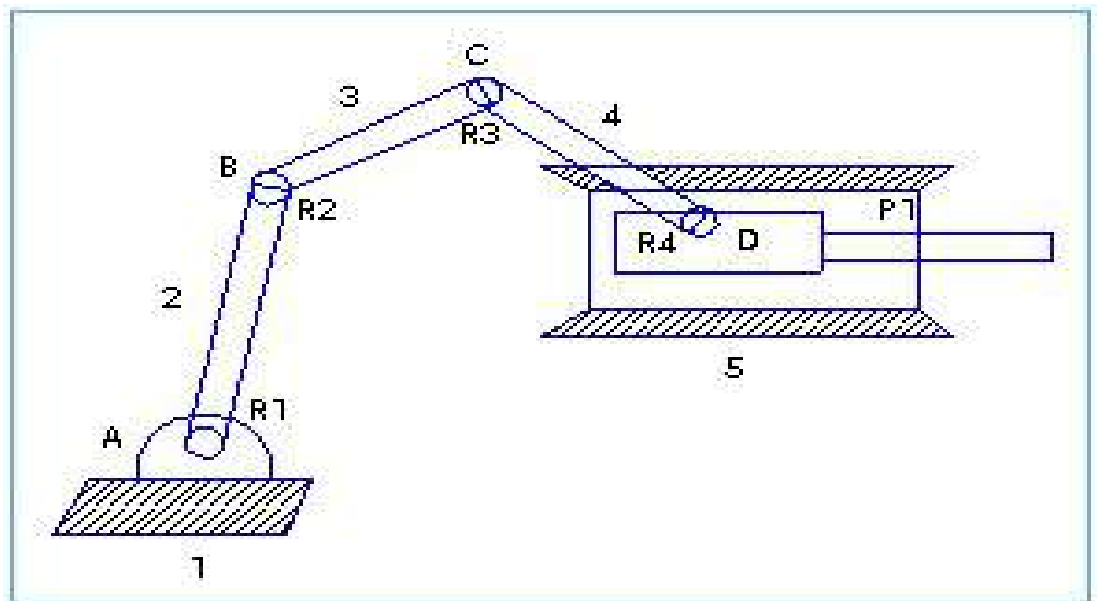

Picture 6.11 Closed chain by a prismatic joint

$$\text{degree of freedom} = 3(n-1) - 2J_R - 2J_p$$

$$\text{degree of freedom} = 3(5-1) - 2(4) - 2(1) = 2 \text{ dof}$$

Example3

$$\text{degree of freedom} = 3(n-1) - 2J_R - 2J_p$$

$$\text{degree of freedom} = 3(5-1) - 2(5) - 2(0) = 2\text{dof}$$

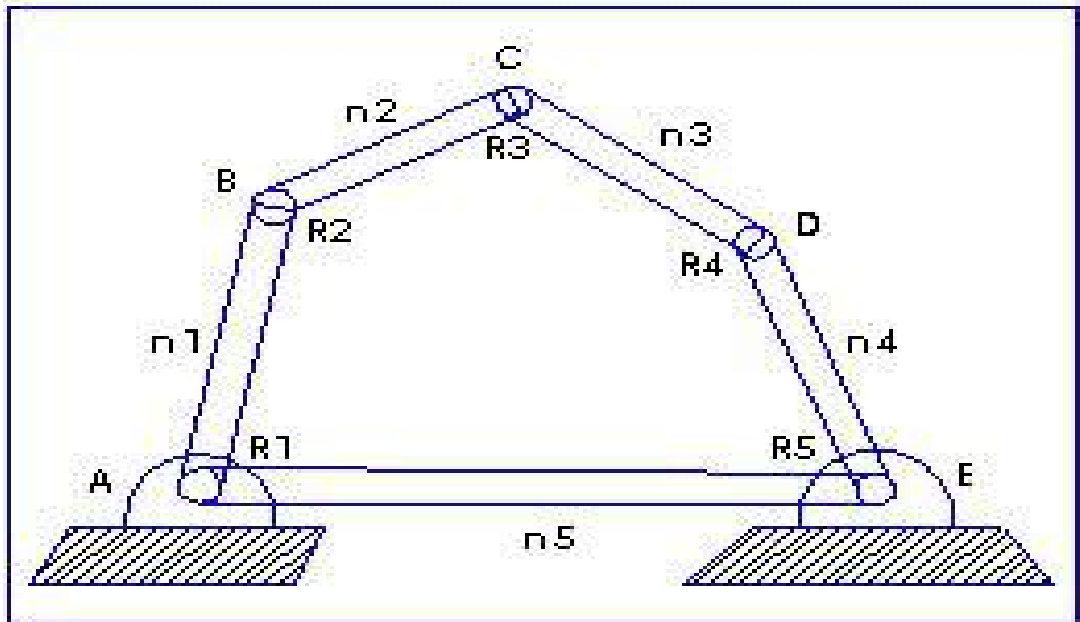

Picture 6.12 Closed chain

## Parallel chains

### 6.7 Stewart platform

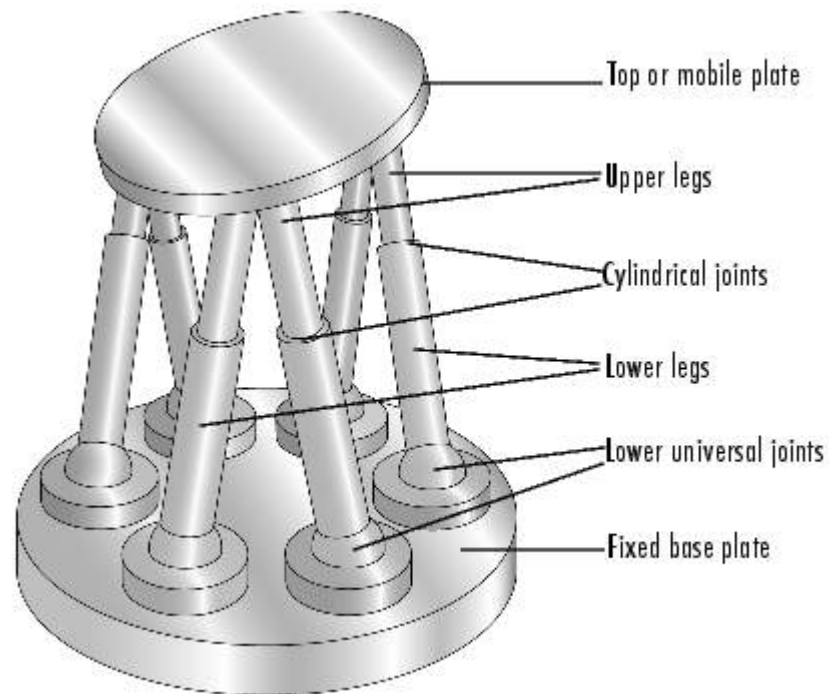

Picture 6.13 Stewart platform

Source: <http://www.mathworks.se/help/toolbox/physics/mech/ug/f15-35077.html>

How to calculate Stewart platform degree of freedom?

$$6(n-1) - 3J_S - 4J_h - 5J_R - 5J_P$$

$J_h$  : number of hooke joints

$J_S$  : number of spherical joints

n: number of linkages.

## 6.8 Defining work space area

There are two types of work space area: parallel work space and perpendicular work space. It is very important to determine work space area and to know the planes of work space. In the picture 6.14 the robot of five degrees of freedom as we can see there are several rotations with two work spaces. First Base and wrist they rotate in parallel work space. Then waist, shoulder and elbow they are rotating in parallel work space to each other. Then base and wrist they rotate in perpendicular work space against waist, shoulder and elbow.

**Spatial manipulator:** that has more planes to move through with more perpendicular and parallel axes to each other like industrial robot as an example in figure 6.14.

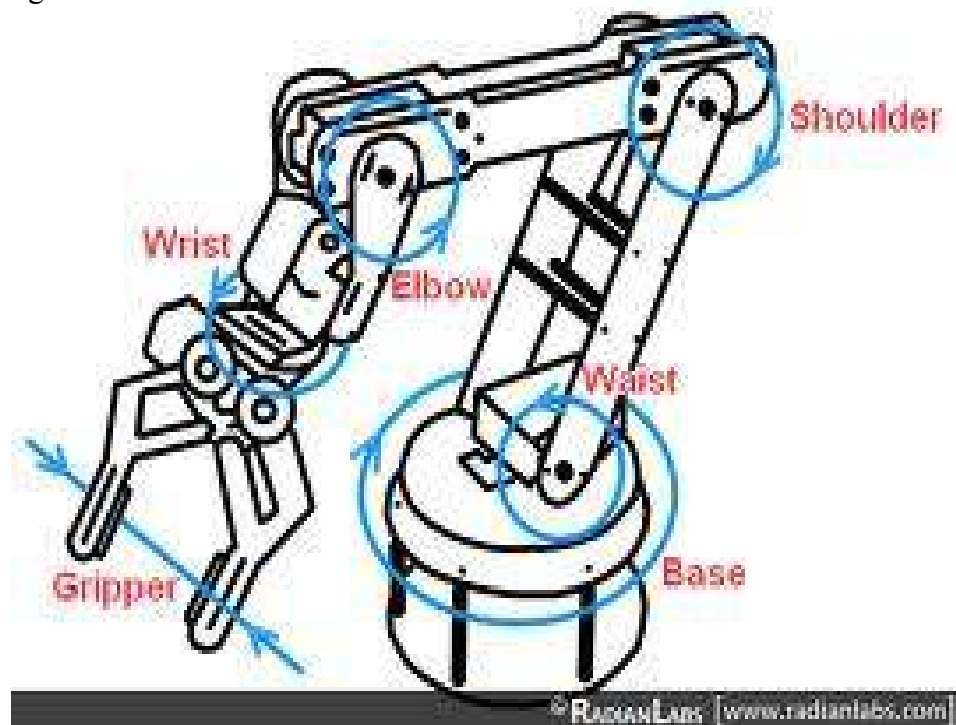

Picture 6.14 Example with spatial robot

Notice: This example is called 5RP manipulator; all these axes are moved with series of cables and pulleys which are connected to the drive motor.

**Manipulator** task is to position an object and to define how many orientations are possible for a specific position. This issue is required for mechanical engineers to answer. By adding more degree of freedom you can add more orientations and ranges of orientation but control problem gets bigger.

**Notice** number of possible orientations (directions) depends on the position of the object.

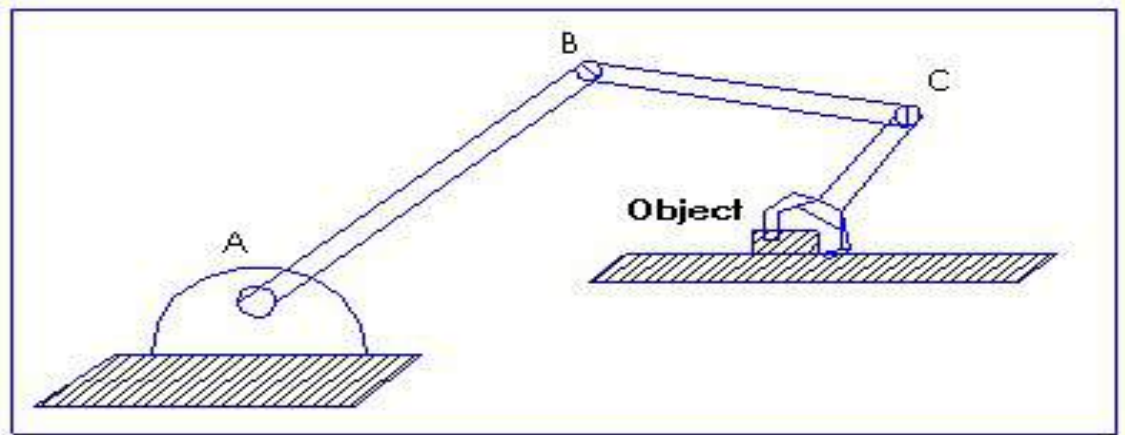

Picture 6.15 Example of positioning an object

In the following picture 6.16 we have just one orientation.

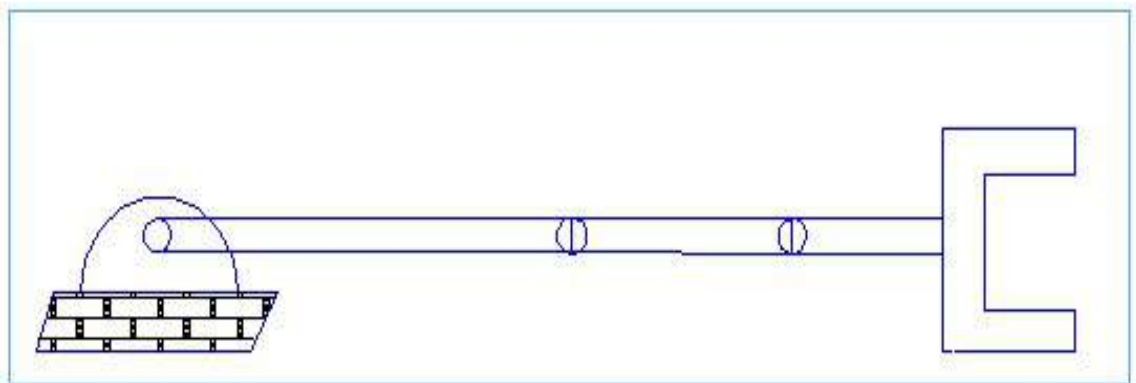

Picture 6.16 one orientation example

**Work space:** we notice from the following picture 6.17 that if B rotates, then work space will be as we see in the picture but if we assume that  $L1 = L2$  then C1 will touch the base A and we notice that we have a bigger workspace (Craig 2005, 102-103.)

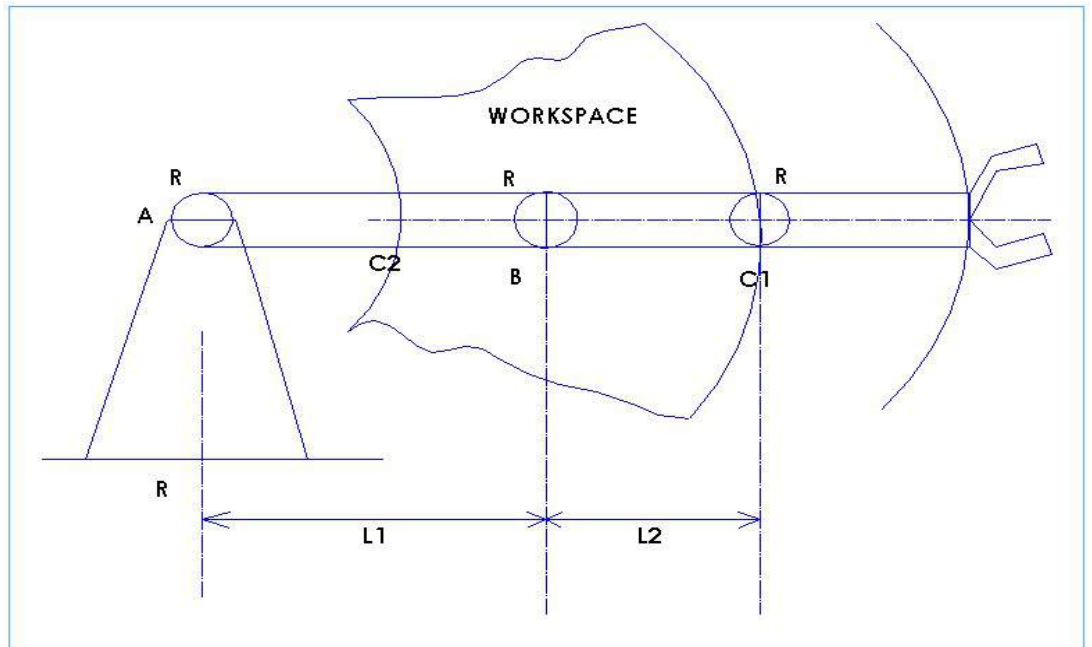

Picture 6.17 Example to show a work space

Direct kinematics in the picture 6.18 and inverse kinematics in picture 6.19

To define the position is easy if we know the value of joint angles  $\theta_a$  and  $\theta_b$  for 2 axis (2R manipulator) robot and this is considered to be an easy task.

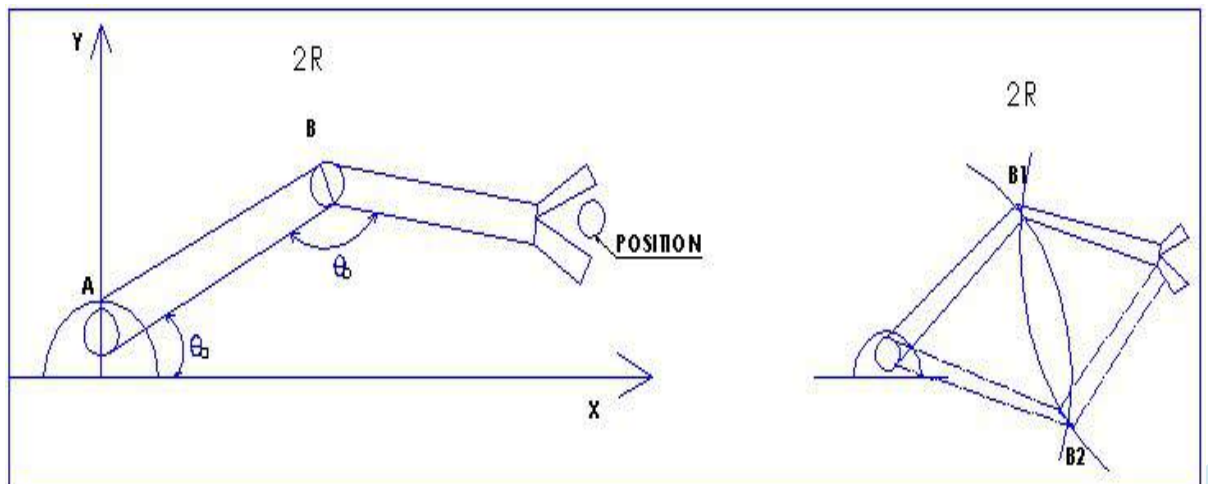

Picture 6.18 Direct kinematics 2R

Picture 6.19 Inverse kinematics 2R

There are 3 axis or 3R manipulator robot in picture 5.6 and 5.7. There is The Inverse kinematics in picture 5.7 and direct kinematics in 5.6 (Craig 2005, 103-104.).

Notice  $\gamma$  is the orientation angle.

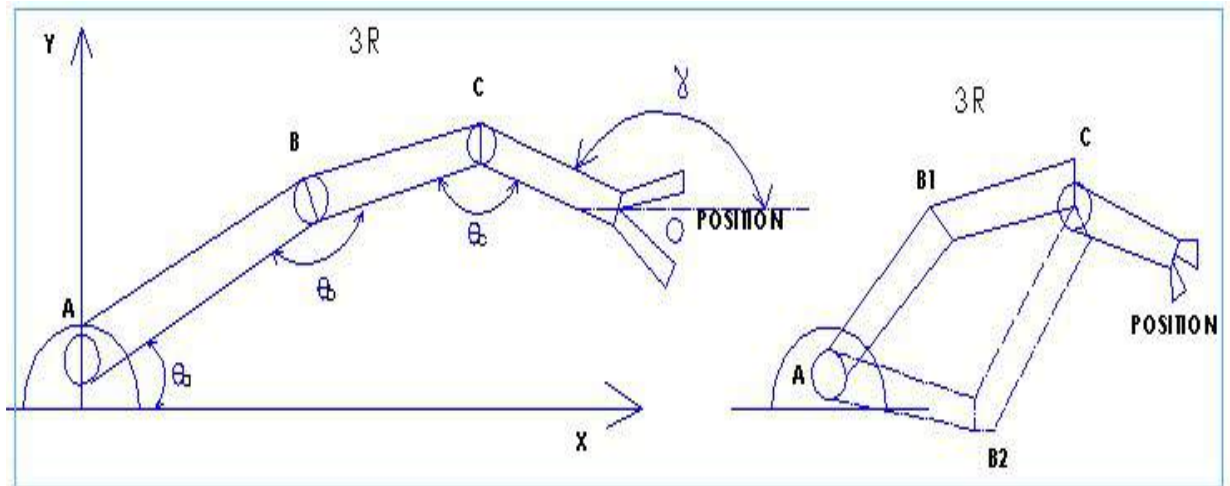

Picture 6.20 Direct kinematics 3R

Picture 6.21 Inverse kinematics 3R

Notice: The given joint angles will define the position of an end effector.

### 6.9 How to define the inverse kinematics in 2R manipulator

When the base position, end effector position and the linkage length are given, then we have unique solution by drawing two circles. The center of these circles is: the position of the base A and the position of the end effector. Then we take the 2 cross point which represents direct kinematics and inverse kinematics solutions.

### 6.10 How to define the inverse kinematics in 3R manipulator

When end effector position and the linkage length are given, then we have unique solution by drawing two circles and the center of these circles is: The position of the base A and the position of C. Notice that the position of C stays the same. (Craig 2005, 102-105.)

## 7 TRAJECTORY DEFINITION

This example is how to move the box from position  $p_1$  to final position  $p_4$  during  $t_1$  to  $t_4$ .

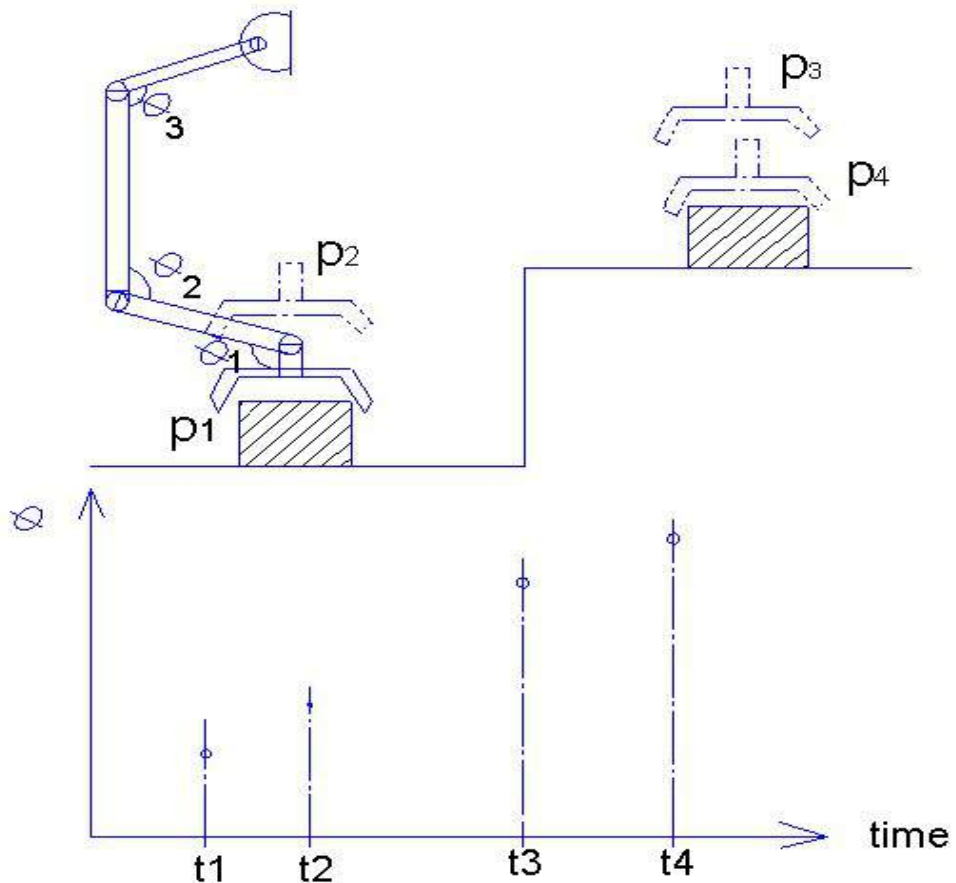

Figure 7.1 Moving object from position 1 to position 4

Solution: First we need to calculate  $\theta$ 's at  $t_1$ ,  $t_2$ ,  $t_3$ ,  $t_4$ . Then we need to calculate the position of the links. This kind of problem can be called inverse kinematics. We should be careful that during motion no accident happens. Given  $\theta$ 's at each moment determines the position and orientation of all links.

## 7.1 Forward position problem

Fixed parameters of the mechanisms values of joint variables will determine position and orientations of all links.

## 7.2 Inverse position problem

Fixed bars of the mechanisms position and orientations of end effector will determine the values of joint variables.

## 7.3 Simple example with planar 2R

- $l_1, l_2$ , lengths and p coordinate is given
- We need to calculate  $\theta$ 's and  $\alpha$ 's(orientations)

$X_B$  and  $Y_B$ : are coordinates of B

$X_P$  and  $Y_P$ : are coordinates of P

$$Y_B = L_1 \sin \theta_1$$

$$X_B = L_1 \cos \theta_1$$

$$X_P = L_1 \cos \theta_1 + L_2 \cos(\theta_1 + \theta_2)$$

$$Y_P = L_1 \sin \theta_1 + L_2 \sin(\theta_1 + \theta_2)$$

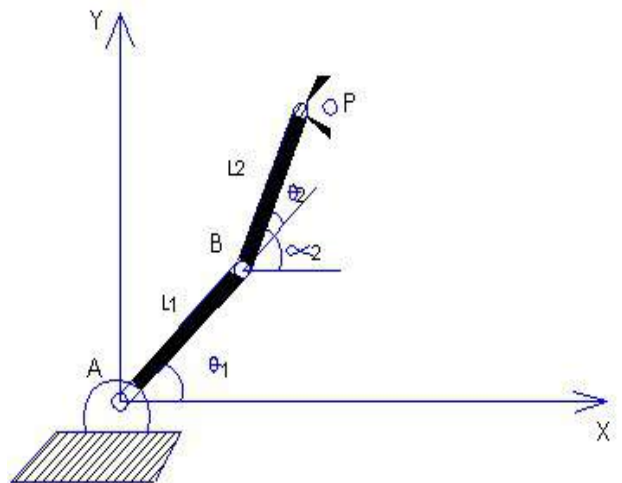

Figure 7.2 2R Manipulator

We need to find the orientation angle for

$X_B$  and  $Y_B$ :  $\alpha_1$

$X_P$  and  $Y_P$ :  $\alpha_2$

$$\alpha_2 = \theta_1 + \theta_2$$

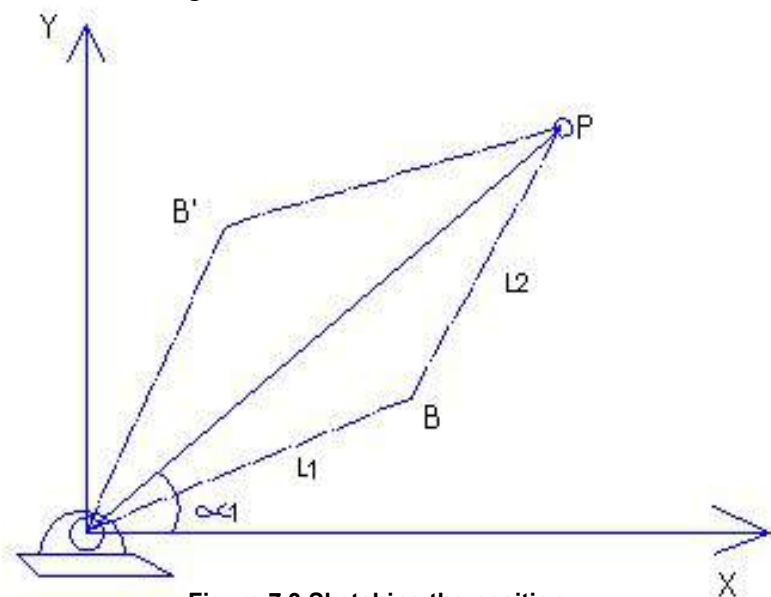

Figure 7.3 Sketching the position

To find  $\theta_1$  we use the following formula:

$$\theta_1 = \text{atan}\left(\frac{Y_P}{X_P}\right) - \text{acos}\left(\frac{L_1^2 + X_P^2 + Y_P^2 - L_2^2}{2L_1\sqrt{X_P^2 + Y_P^2}}\right)$$

### Example1:

This is a numerical example for 2 planar:

$$L_1 = 4.5, L_2 = 4.5,$$

$$Y_P = 4, X_P = 6$$

$$\theta_1 = \text{atan}\left(\frac{Y_P}{X_P}\right) - \text{acos}\left(\frac{L_1^2 + X_P^2 + Y_P^2 - L_2^2}{2L_1\sqrt{X_P^2 + Y_P^2}}\right)$$

$$\theta_1 = \text{atan}\left(\frac{4}{6}\right) - \text{acos}\left(\frac{4.5^2 + 6^2 + 4^2 - 4.5^2}{2 \cdot 4.5 \sqrt{6^2 + 4^2}}\right)$$

$$\theta_1 = -3^\circ$$

First we extend line from the end of first link to the position of  $Y_P, X_P$ , then the second link should give us the same length as 4.5 to prove that our calculation is right. Now we can measure the value of  $\theta_2$  which is  $73.34^\circ$ .

$$\tan \kappa_1 = \left(\frac{Y_P}{X_P}\right) = \left(\frac{4}{6}\right) = 33.69^\circ$$

$$\kappa_2 = \theta_1 + \theta_2$$

$$\kappa_2 = -3 + 73.34 = 70.34$$

We got the values of  $\theta_1, \theta_2, \kappa_1, \kappa_2$

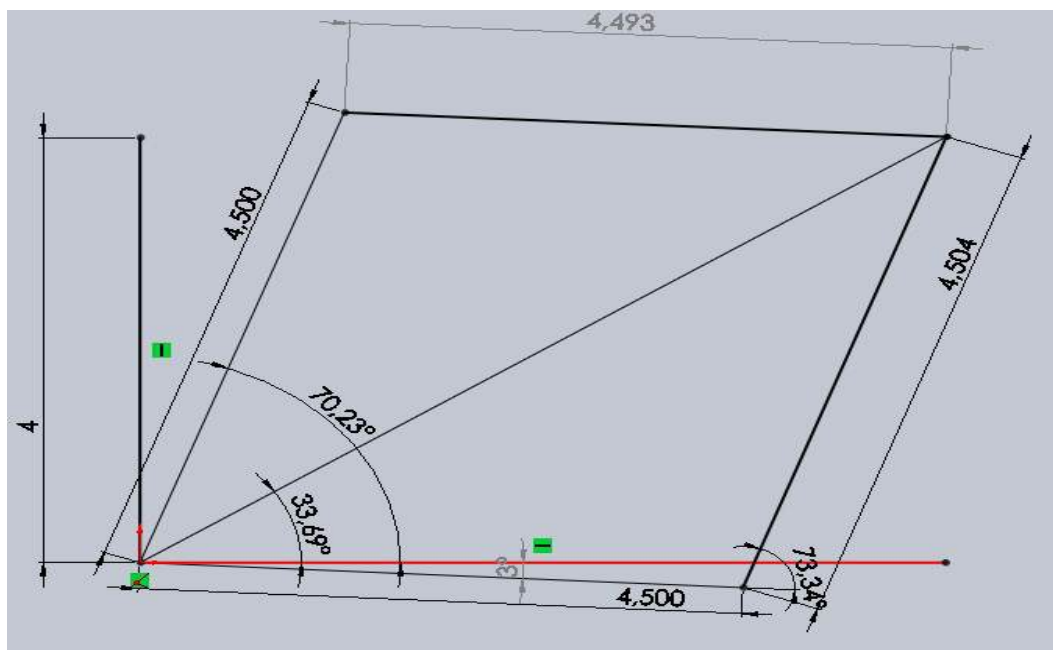

Figure 7.4 The solution drawn in SolidWorks

## 7.4 3R planar manipulator

- $l_1, l_2, l_3, X_p, Y_p$  and  $\alpha_3$  are given
- we need to calculate  $\theta_1, \theta_2, \theta_3$
- first we need to define  $Y_c, X_c$

$$\begin{aligned} Y_c &= Y_p - L_3 \sin \alpha_3 \\ X_c &= X_p - L_3 \cos \alpha_3 \end{aligned}$$

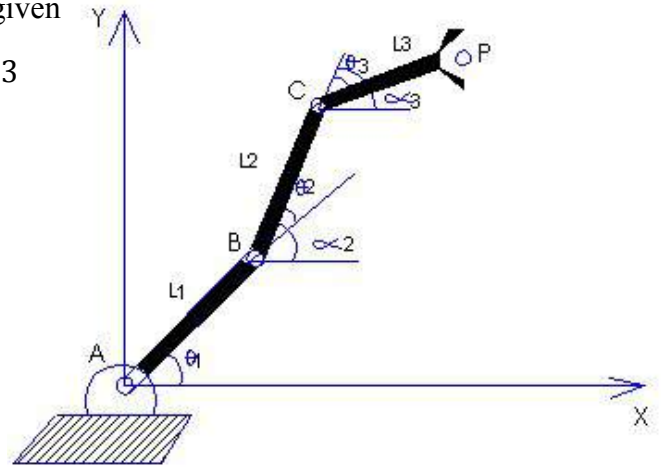

Figure 7.5 3R Manipulator

$$\theta_3 = \alpha_3 - (\theta_1 + \theta_2)$$

First we define  $Y_c, X_c$ , then we calculate

$\theta_1$  and  $\theta_2$ , the same way like 2 planar manipulator

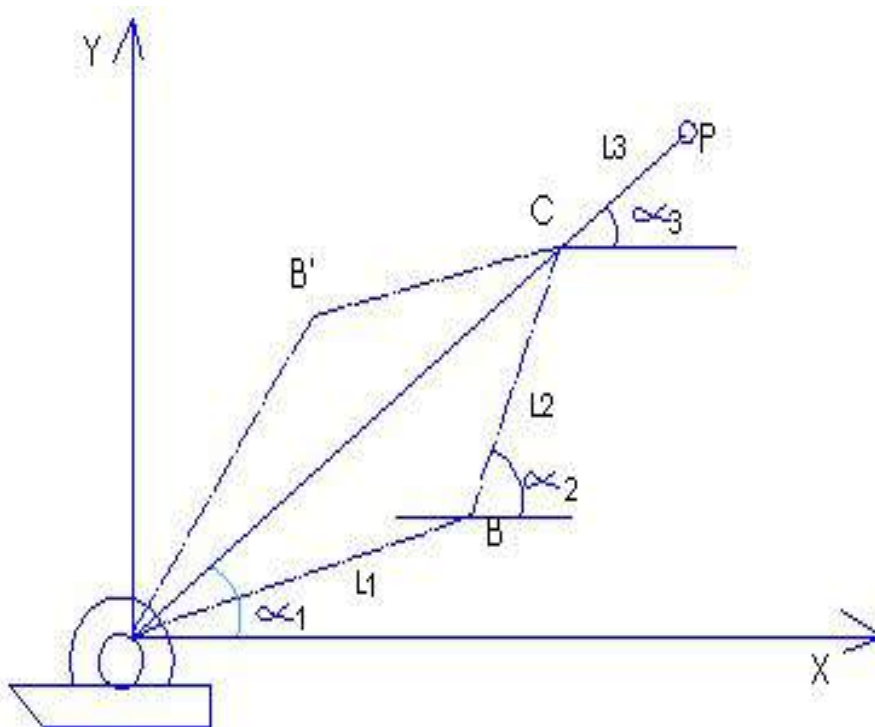

Figure 7.6 Sketching the position for 3R manipulator

### Example 2:

For 3 planar manipulator

$\ell_1, \ell_2, \ell_3, X_p, Y_p$  and  $\alpha_3$  are given

$\ell_1 = 5, \ell_2 = 5, \ell_3 = 2, X_p = 8$  and  $Y_p = 7$

First we calculate  $\alpha_3$  to define  $X_c$  and  $Y_c$

$$\tan \alpha_3 = \left(\frac{Y_p}{X_p}\right) = \left(\frac{7}{8}\right) = 41.19^\circ$$

$$Y_c = Y_p - L_3 \sin \alpha_3 = 7 - 2 * \sin 41.19^\circ = 5.68$$

$$X_c = X_p - L_3 \cos \alpha_3 = 8 - 2 * \cos 41.19^\circ = 6.49$$

Now we need to define  $\theta_1$

$$\theta_1 = \operatorname{atan}\left(\frac{Y_c}{X_c}\right) - \operatorname{acos}\left(\frac{L_1^2 + X_c^2 + Y_c^2 - L_2^2}{2L_1 \sqrt{X_c^2 + Y_c^2}}\right)$$

$$\theta_1 = \operatorname{atan}\left(\frac{5.68}{6.49}\right) - \operatorname{acos}\left(\frac{5^2 + 6.49^2 + 5.68^2 - 5^2}{2 * 5 \sqrt{6.49^2 + 5.68^2}}\right)$$

$$\theta_1 = 10.79^\circ$$

Now we can extend line from the end of first link to the position of  $Y_p, X_p$  then the second link should give us the same length as 5 to prove that our calculation is right. Now we can measure the value of  $\theta_2$  which is  $60.70^\circ$

$$\tan \alpha_1 = \left(\frac{Y_p}{X_p}\right) = \left(\frac{5.68}{6.49}\right) = 41.19^\circ$$

$$\alpha_2 = \theta_1 + \theta_2$$

$$\alpha_2 = 10.79^\circ + 60.70^\circ = 71.49^\circ$$

We got the values of  $\theta_1, \theta_2, \alpha_1, \alpha_2, \alpha_3$

$$\theta_3 = \alpha_3 - (\theta_1 + \theta_2)$$

$$\theta_3 = 41.19^\circ - (10.79^\circ + 60.70^\circ)$$

$$\theta_3 = 30.3^\circ$$

We can see the result of our calculation in the figure 10.7 on the following page.

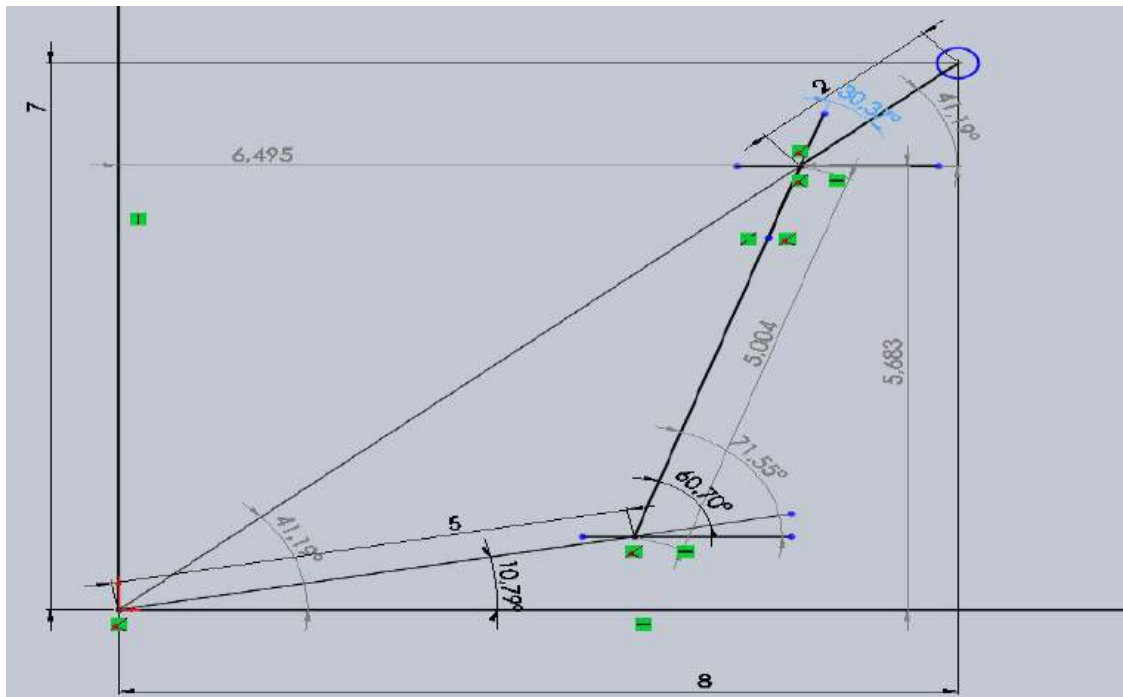

Figure 7.7 Sketching the position in SolidWorks

## 7.5 Prismatic joints calculation

3p manipulator

We assume according to the following drawing that we have three prismatic joints which move in 3D space so we just need to find values of  $S_1$ ,  $S_2$  and  $S_3$ .

$$S_1 = X_p$$

$$S_2 = Y_p$$

$$S_3 = Z_p$$

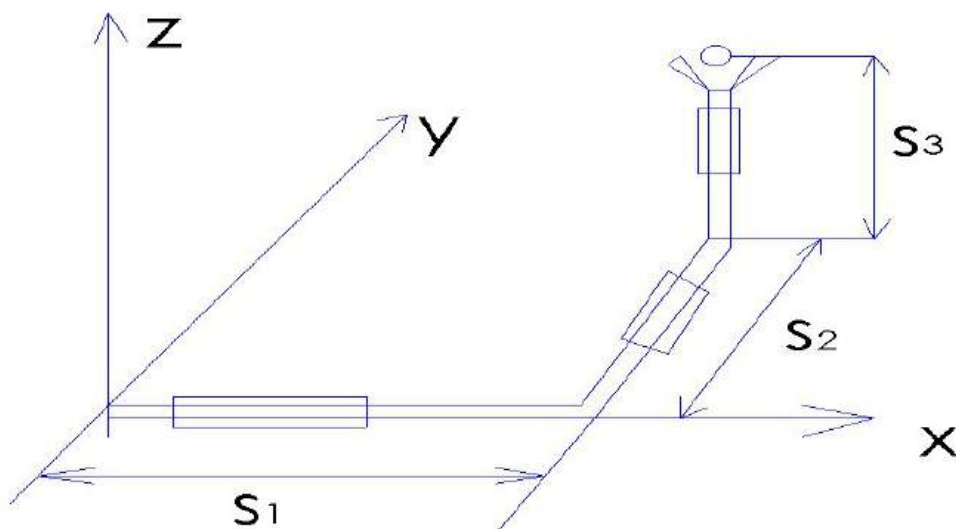

Figure 7.8 Prismatic joints manipulator

## 8 POSITION, ORIENTATION, FRAMES

### 8.1 Introduction

In this section I will try to summarize how to define position coordinate on the space with respect to the origin frame and to calculate the transformation when this frame rotates with respect to the base frame.

There is frame A and frame B.

Frame B rotates with respect to frame A

1. Find rotation B in A?
2. Find the coordinate  $P^A$ ?

The coordinate of p (0 3 1)

The coordinate of  $p_B$  (0 1 1)

$${}^A_B R = \begin{pmatrix} X_B X_A & Y_B X_A & Z_B X_A \\ X_B Y_A & Y_B Y_A & Z_B Y_A \\ X_B Z_A & Z_B Z_A & Z_B Z_A \end{pmatrix}$$

$${}^A_B R = \begin{pmatrix} 1 * 1 & 1 * 0 & 1 * 0 \\ 1 * 0 & 1 * 0 & 1 * -1 \\ 1 * 0 & 1 * 1 & 1 * 0 \end{pmatrix}$$

$${}^A_B R = \begin{pmatrix} 1 & 0 & 0 \\ 0 & 0 & -1 \\ 0 & 1 & 0 \end{pmatrix}$$

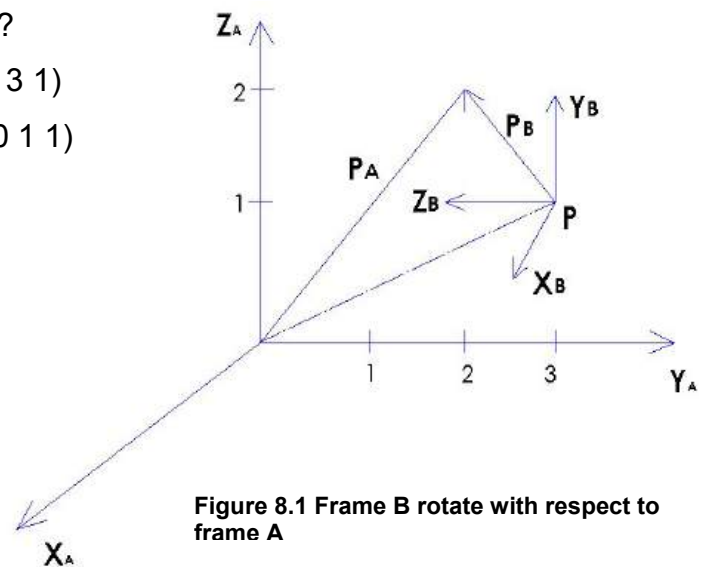

Figure 8.1 Frame B rotate with respect to frame A

**Now we need to find the translation.**

We add extra row which represents rotation axis (0 0 0 1), then we make dot product between rotation matrix and the coordinate of  $p_B$  (0 1 1) and then we get the coordinate of  $P^A$  (Tapani Kuusi, lecture on Lahti University of Applied Sciences 2010).

$P^A$

$${}^A T = {}^A_B R * p_B$$

$${}^A T_B = \begin{pmatrix} 1 & 0 & 0 & 0 \\ 0 & 0 & -1 & 3 \\ 0 & 1 & 0 & 1 \\ 0 & 0 & 0 & 1 \end{pmatrix} * \begin{pmatrix} 0 \\ 1 \\ 1 \\ 1 \end{pmatrix} = \begin{pmatrix} 0 \\ 2 \\ 2 \\ 1 \end{pmatrix}$$

$$P^A = (0 \ 2 \ 2 \ 1)$$

Then we drop the last coordinate which represents rotation axis so we get (0 2 2).

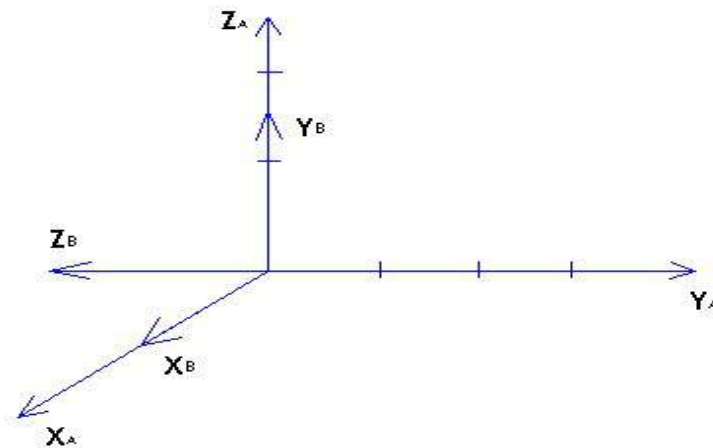

Figure 8.2

Example 2:

There is rotation from P to P<sub>2</sub> around X axis

$$R_x(\theta) = \begin{pmatrix} 1 & 0 & 0 \\ 0 & \cos \theta & -\sin \theta \\ 0 & \sin \theta & \cos \theta \end{pmatrix}$$

$$P_2 = R_x(\theta) * P$$

$$P_2 = \begin{pmatrix} 1 & 0 & 0 \\ 0 & 0.8 & -0.6 \\ 0 & 0.6 & 0.8 \end{pmatrix} * \begin{pmatrix} 0 \\ 2 \\ 1 \end{pmatrix} = \begin{pmatrix} 0 \\ 1 \\ 2 \end{pmatrix}$$

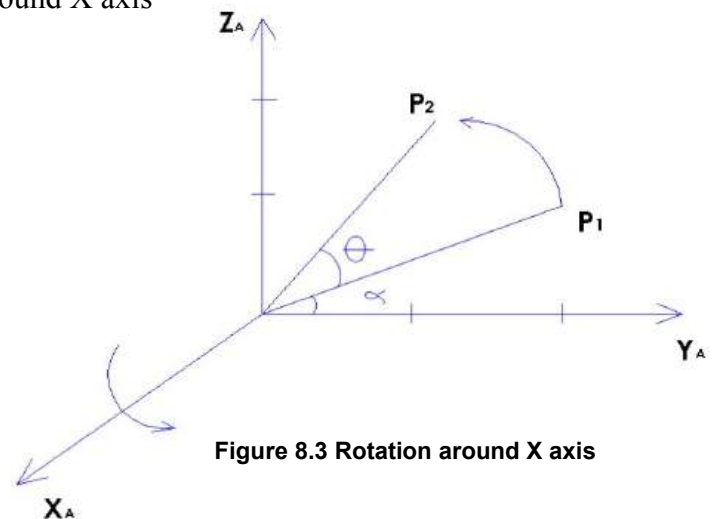

Figure 8.3 Rotation around X axis

(Tapani Kuusi, lecture on Lahti University of Applied Sciences 2010)

### Example

In the following example frame B rotates with respect to frame A.

We have 3 different rotations.

1. Rotation around X axis which rotates with angle  $\gamma$
2. Rotation around y axis which rotates with angle  $\alpha$
3. Rotation around z axis which rotates with angle  $\beta$

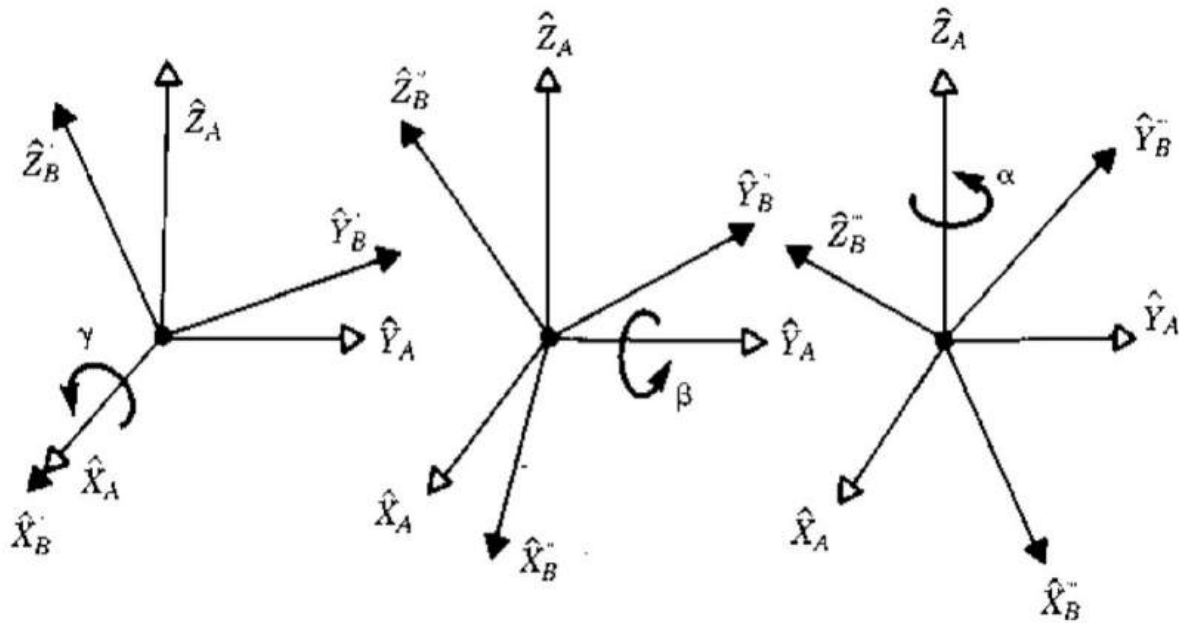

**Figure 8.4 Rotation axes**  
(Craig 2005, 42)

$${}^A_B R_{XYZ}(\gamma, \beta, \alpha) = R_Z(\alpha) * R_Y(\beta) * R_X(\gamma)$$

$${}^A_B R_{XYZ}(\gamma, \beta, \alpha) = \begin{pmatrix} C\alpha & -S\alpha & 0 \\ S\alpha & C\alpha & 0 \\ 0 & 0 & 1 \end{pmatrix} \begin{pmatrix} C\beta & 0 & S\beta \\ 0 & 1 & 0 \\ -S\beta & 0 & C\beta \end{pmatrix} \begin{pmatrix} 1 & 0 & 0 \\ 0 & C\gamma & -S\gamma \\ 0 & S\gamma & C\gamma \end{pmatrix}$$

Notice:

1. that  $C\alpha$  and  $S\alpha$  is a shorthand for  $\cos \alpha$  and  $\sin \alpha$
2. It is important to pay attention to the order of rotation since we begin with  $R_x$  then  $R_y$  and finally  $R_z$ . When we take the product we begin with the last rotation toward the previous one.

$${}^A R_{XYZ}(\gamma, \beta, \alpha) = \begin{pmatrix} C\alpha C\beta & C\alpha S\beta S\gamma - S\alpha C\gamma & C\alpha S\beta C\gamma + S\alpha S\gamma \\ S\alpha C\beta & S\alpha S\beta S\gamma + C\alpha C\gamma & S\alpha S\beta C\gamma - C\alpha S\gamma \\ -S\beta & C\beta S\gamma & C\beta C\gamma \end{pmatrix}$$

**Important Notice:** How we can make the calculation for B rotating around A? It sounds like a difficult question but actually it is easy to answer, we just need to get the transpose of the matrix  ${}^A R = [{}^B R]^T = [{}^B R]^{-1}$

$$[{}^B R]_{XYZ}(\gamma, \beta, \alpha) = \begin{pmatrix} C\alpha C\beta & S\alpha C\beta & -S\beta \\ C\alpha S\beta S\gamma - S\alpha C\gamma & S\alpha S\beta S\gamma + C\alpha C\gamma & C\beta S\gamma \\ C\alpha S\beta C\gamma + S\alpha S\gamma & S\alpha S\beta C\gamma - C\alpha S\gamma & C\beta C\gamma \end{pmatrix}$$

(Craig 2005, 42)

## 8.2 Transformation

We use matrices to transform vectors.

Example:

In the following picture frame B rotates around frame A about z axis by  $30^\circ$   
 Here Z axis is pointing out of the page  ${}^B P (0 \ 2 \ 0)$  (Craig 2004, 26-27.)

$${}^A R_B = \begin{pmatrix} C\alpha & -S\alpha & 0 \\ S\alpha & C\alpha & 0 \\ 0 & 0 & 1 \end{pmatrix}$$

$${}^A R_B = \begin{pmatrix} C30 & -S30 & 0 \\ S30 & C30 & 0 \\ 0 & 0 & 1 \end{pmatrix}$$

$${}^A R_B = \begin{pmatrix} 0,866 & -0,5 & 0 \\ 0,5 & 0,866 & 0 \\ 0 & 0 & 1 \end{pmatrix}$$

We calculate  ${}^A P$

$${}^A P = {}^A R_B {}^B P$$

$${}^A P = \begin{pmatrix} 0,866 & -0,5 & 0 \\ 0,5 & 0,866 & 0 \\ 0 & 0 & 1 \end{pmatrix} \begin{pmatrix} 0 \\ 2 \\ 0 \end{pmatrix}$$

$${}^A P = \begin{pmatrix} -1 \\ 1,73 \\ 0 \end{pmatrix}$$

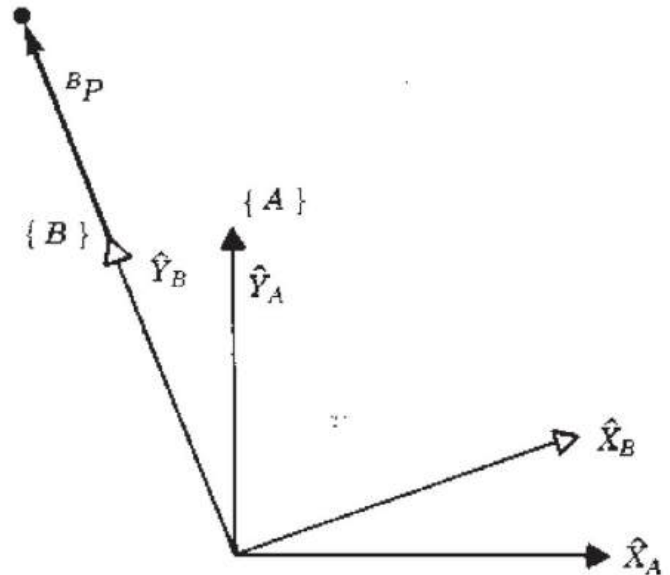

**Figure 8.5**  
(Craig 2005, 26)

### 8.3 Mapping involving general frames

We need to know how we can get the parameters of  ${}^A P$  which parameters are given in frame B and the parameters of  ${}^A P_{BORG}$  are given (Craig 2005, 27-28).

We use the following formula (Craig 2005, 27).

$${}^A P = {}^A R {}^B P + {}^A P_{BORG}$$

$${}^A P = {}^A T {}^B P$$

$$\begin{bmatrix} {}^A P \\ 1 \end{bmatrix} = \begin{bmatrix} {}^A R & {}^A P_{BORG} \\ 0 & 1 \end{bmatrix} \begin{bmatrix} {}^B P \\ 1 \end{bmatrix}$$

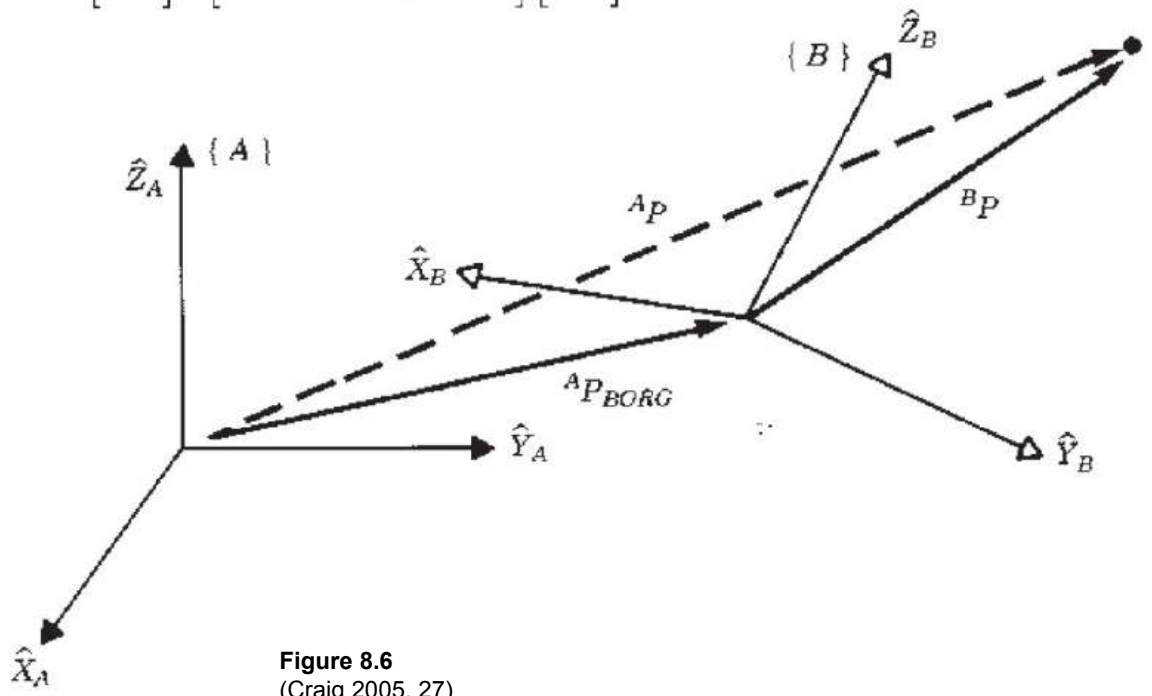

Figure 8.6  
(Craig 2005, 27)

**We notice**

1. That we add just for rotation matrix one row of zeros (0 0 0).
2. For vector's coordinates we add number 1 below all of them.
3. This kind of matrix is called homogeneous transform (4x4).

**Example:**

Frame B has rotated with relative to frame A bout Z axis by 30 degrees and translated 10 units in  $X_A$ , and 5 units in  $Y_a$ .

Find  ${}^A P$  where  ${}^B P = (3 \ 7 \ 0)^T$  (Craig 2005, 29).

The definition of frame B is

$${}^A T_B = \begin{bmatrix} 0.866 & -0.500 & 0.000 & 10.0 \\ 0.500 & 0.866 & 0.000 & 5.0 \\ 0.000 & 0.000 & 1.000 & 0.0 \\ 0 & 0 & 0 & 1 \end{bmatrix}$$

Given

$${}^B P = \begin{bmatrix} 3 \\ 7 \\ 0 \end{bmatrix}$$

$${}^A P = {}^A T_B {}^B P$$

$${}^A P = \begin{bmatrix} 9 \\ 12.5 \\ 0 \end{bmatrix}$$

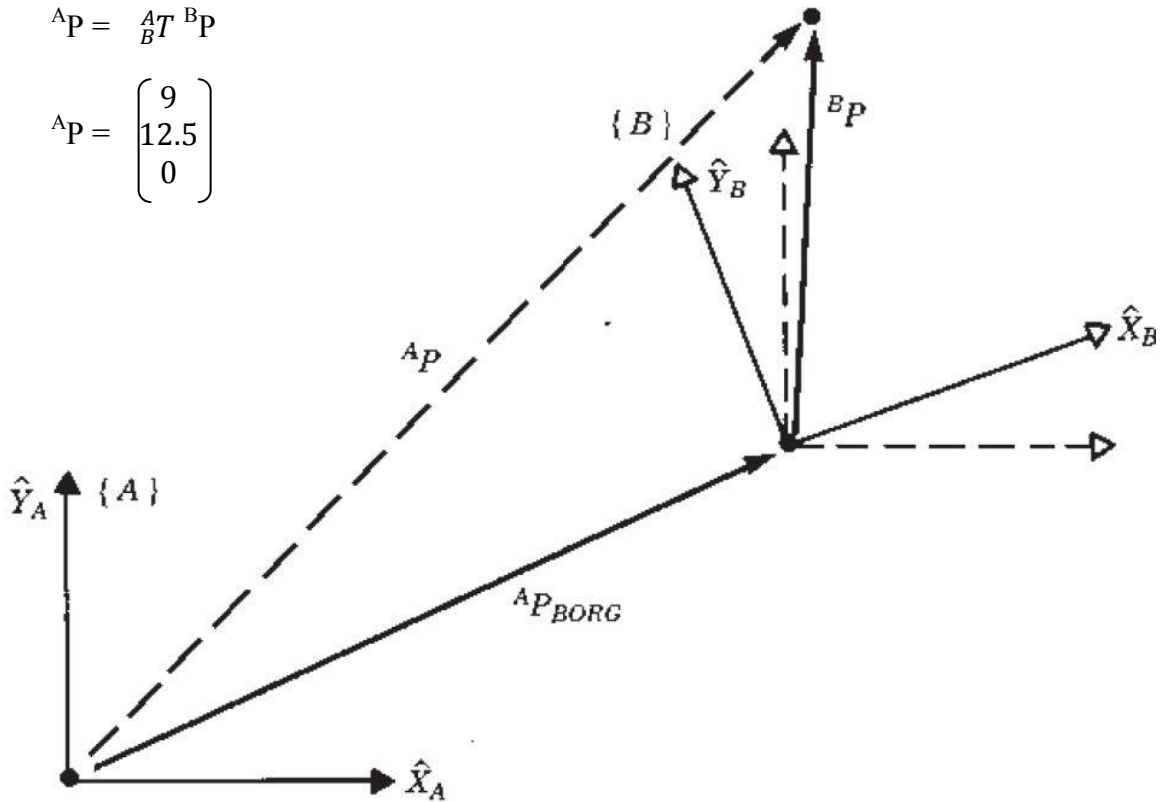

Figure 8.7  
(Craig 2005, 29)

## 8.4 Translation operators

Operator is the same like rotation and translation but the interpretation is different.

Example of operator:

According to the following picture the vector  ${}^A P_1$  is rotated around Z axis by 30 degrees and translate it 10 units in  $X_A$  and 5 units in  $Y_a$ .

Find  ${}^A P_2$  when the coordinate of  ${}^A P_1$  is  $(3 \ 7 \ 0)^T$  (Craig 2005, 33).

Solution:

The operator T which performs the rotation and translation is:

$$T = \begin{bmatrix} 0.866 & -0.500 & 0.000 & 10.0 \\ 0.500 & 0.866 & 0.000 & 5.0 \\ 0.000 & 0.000 & 1.000 & 0.0 \\ 0 & 0 & 0 & 1 \end{bmatrix}$$

Then

$${}^A P_2 = T {}^A P_1$$

$${}^A P_2 = \begin{bmatrix} 0.866 & -0.500 & 0.000 & 10.0 \\ 0.500 & 0.866 & 0.000 & 5.0 \\ 0.000 & 0.000 & 1.000 & 0.0 \\ 0 & 0 & 0 & 1 \end{bmatrix} \begin{bmatrix} 3 \\ 7 \\ 0 \\ 1 \end{bmatrix}$$

$${}^A P_2 = \begin{bmatrix} 9 \\ 12.5 \\ 0 \end{bmatrix}$$

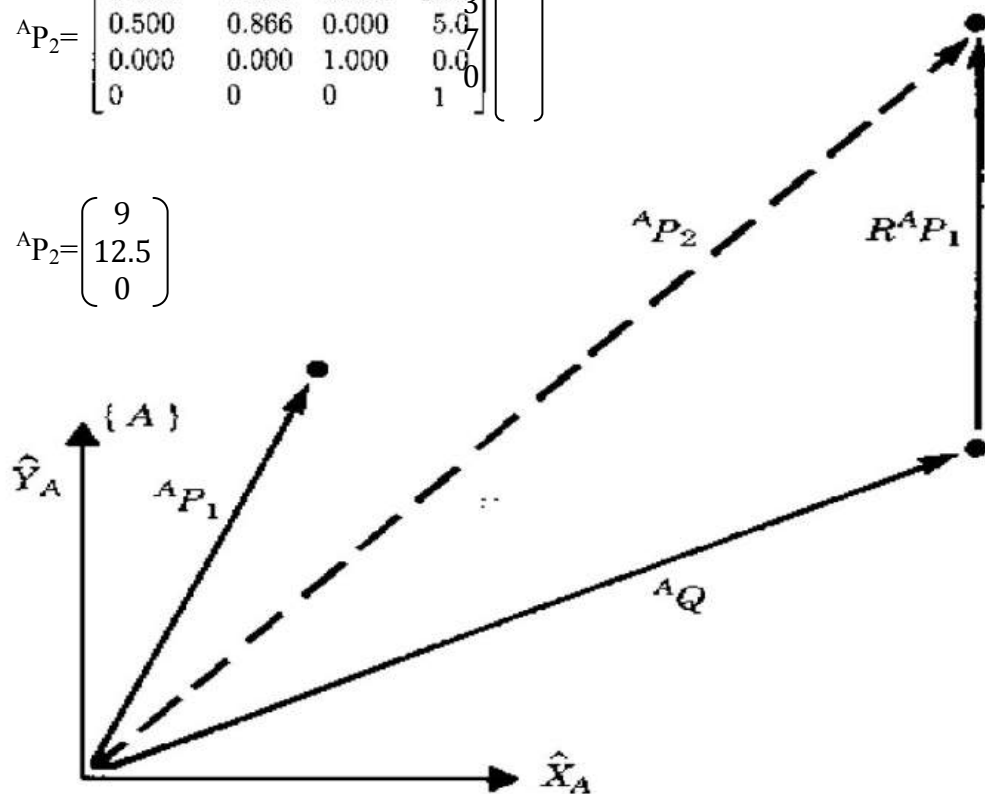

Figure 8.8  
(Craig 2005, 33)

## 8.5 Compound transformation

In this picture we have  ${}^C P$  and we want to find  ${}^A P$ .

**Notice:** Frame C is relative to frame B and frame B is relative to frame A.

We transform  ${}^C P$  into  ${}^B P$  (Craig 2005, 34-35).

$${}^B P = {}^B T {}^C P$$

Then we transform  ${}^B P$  into  ${}^A P$

$${}^A P = {}^A T {}^B P$$

Then we combine them together to get

$${}^A P = {}^A T {}^B T {}^C P$$

$${}^A T = {}^A T {}^B T$$

$${}^A T = \begin{bmatrix} {}^A R {}^B R & | & {}^A R {}^B P_{CORG} + {}^A P_{BORG} \\ \hline 0 & 0 & 0 & | & 1 \end{bmatrix}$$

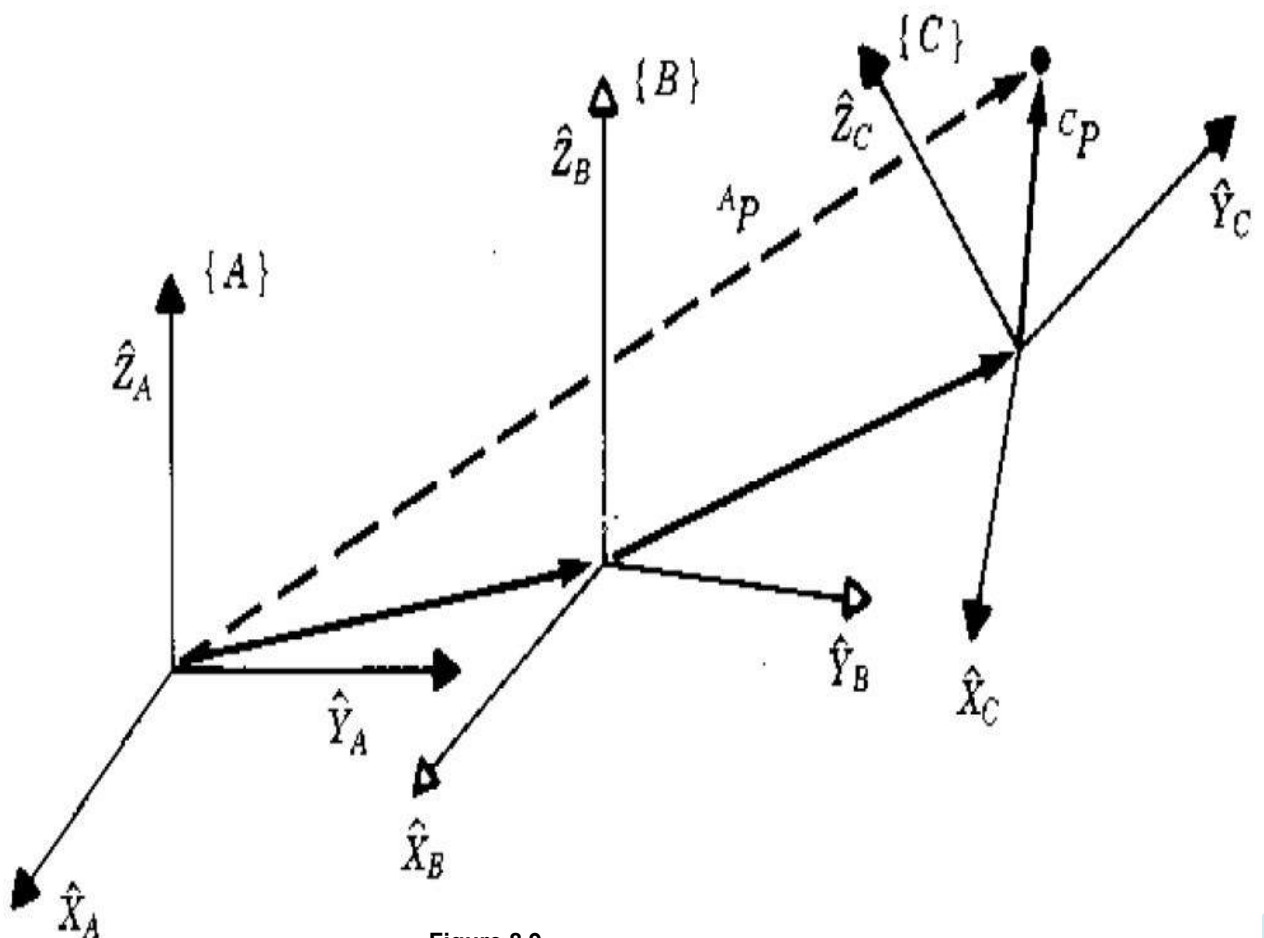

Figure 8.9  
(Craig 2005, 34-35)

## 9 TRAJECTORY PLANNING IN ROBOTICS

### 9.1 Introduction

In this section I will try to cover how to make a path around trajectory, the base of creating path, what is the required data for creating path and how we can make the system to choose the speed, also time and acceleration when we just define the basic required data for trajectory planning.

### 9.2 Required data for trajectory planning

When we think about trajectory we mainly focus in moving object from position A to position B.

In trajectory planning we try to define first the following data

- Initial point
- Final point
- Via point: intermediate point between initial and final points.

Point to point planning is a continuous path motion like in welding for example.

How we plan point to point: First we define task specification.

Mapping:

- World coordinate
- Joint space  $\theta$

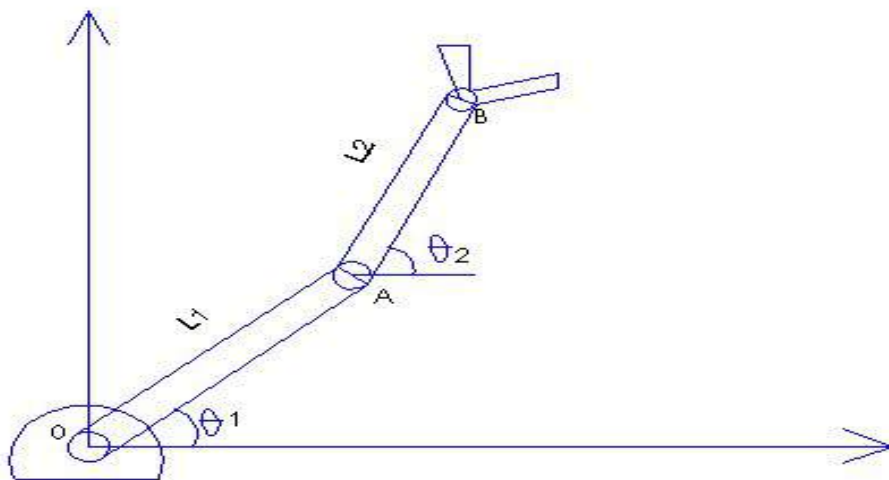

Figure 9.1

$$X_B \leftrightarrow \theta_1$$

$$Y_B \leftrightarrow \theta_2$$

$$X_B = \ell_1 \cos \theta_1 + \ell_2 \cos \theta_2 \quad (\text{equation 1})$$

$$Y_B = \ell_1 \sin \theta_1 + \ell_2 \sin \theta_2 \quad (\text{equation 2})$$

Given  $\theta_1, \theta_2 \rightarrow X_B, Y_B$  (linear algebra)

So we need to define the value of  $\theta_1, \theta_2$  to achieve certain position in B.

$\ell_1, \ell_2$  are given.

Given  $X_B, Y_B \rightarrow$  to find  $\theta_1, \theta_2$  (nonlinear algebra)

To find the speed of motion we need to derivate the 1 and 2 equation:

$$X'_B = -\ell_1 \theta'_1 \sin \theta_1 - \ell_2 \theta'_2 \sin \theta_2 \quad (\text{equation 3})$$

$$Y'_B = \ell_1 \theta'_1 \cos \theta_1 + \ell_2 \theta'_2 \cos \theta_2 \quad (\text{equation 4})$$

This is speed matrix

$$\begin{bmatrix} X'_B \\ Y'_B \end{bmatrix} = \begin{bmatrix} -\ell_1 \sin \theta_1 & -\ell_2 \sin \theta_2 \\ \ell_1 \cos \theta_1 & \ell_2 \cos \theta_2 \end{bmatrix} \begin{Bmatrix} \theta'_1 \\ \theta'_2 \end{Bmatrix} \quad (\text{equation 5})$$

$$C = \begin{bmatrix} -\ell_1 \sin \theta_1 & -\ell_2 \sin \theta_2 \\ \ell_1 \cos \theta_1 & \ell_2 \cos \theta_2 \end{bmatrix}$$

Notice that the system decides the speed and the acceleration as well when we just define the value of  $\theta'_s$

$$\theta' = [C]^{-1} \{x'\} \quad (\text{equation 6})$$

Notice: In case there is no inverse, it means the task is not achievable.

They are the Joint space for trajectory planning  $(\theta_1, \theta_2, \theta_3)$  (Craig 2005, 201-203).

### 9.3 Constraints

In order to make smooth motion we need to put some constraints between via points

- $a$  max (acceleration)
- Torque

Robot should Move from initial points to final points through via points because of intermediate point (obstacles) within specified duration of time.

### 9.4 Subject to constraints

- joint space trajectory planning
- single joint revolute  $\theta(t)$
- move position initial  $i$  to final position  $j$

$i = \theta_i, \theta_i', \theta_i''$

$j = \theta_j, \theta_j', \theta_j''$

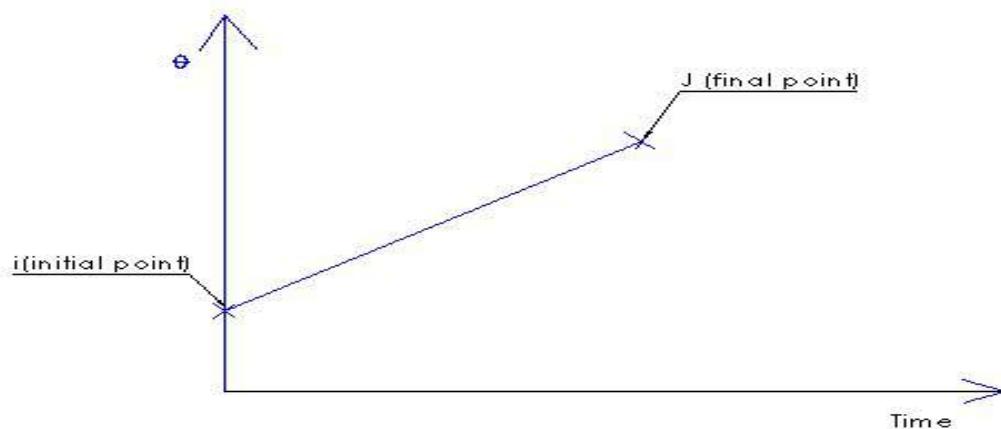

Figure 9.2

### 9.5 Cubic polynomials

$\tau$  : Local time frame

$T_{ij}$ : the duration time

From  $i \rightarrow j$

$\tau \rightarrow 0 : T_{ij}$

$$\theta(\tau) = C_0 + C_1 \tau + C_2 \tau^2 + C_3 \tau^3 \dots \dots \dots + C_n \tau^n \quad \text{(equation 7)}$$

$C$ : velocity

Specified  $\theta_i, \theta_i', \theta_j, \theta_j'$

Specified  $\theta_i, \theta_i', \theta_i'', \theta_j, \theta_j', \theta_j''$

we have 6 coefficients  $C_0 - C_5$

Case:

$$\theta(\tau) = C_0 + C_1 \tau + C_2 \tau^2 + C_3 \tau^3$$

$$\theta(0) = \theta_i \qquad \theta'(0)_i = \theta_i'$$

$$\theta(T_{ij}) = \theta_j \qquad \theta'(T_{ij}) = \theta_j'$$

$$\theta_i = C_0 \rightarrow \theta(\tau) = C_0 + C_1 \tau + C_2 \tau^2 + C_3 \tau^3$$

$$\theta_i' = C_1 \rightarrow \theta'(\tau) = C_1 + 2C_2 \tau + 3C_3 \tau^2 \qquad \text{(equation 8)}$$

$$\theta_j = C_0 + C_1 T_{ij} + C_2 T_{ij}^2 + C_3 T_{ij}^3 \qquad \text{(equation 9)}$$

$$\theta_j' = C_1 + 2C_2 T_{ij} + 3C_3 T_{ij}^2 \qquad \text{(equation 10)}$$

$$C_2 = \frac{3}{t_f^2}(\theta_j - \theta_i) \qquad \text{(equation 11)}$$

$$C_3 = -\frac{3}{t_f^3}(\theta_j - \theta_i) \qquad \text{(equation 12)}$$

Cubic curve fit

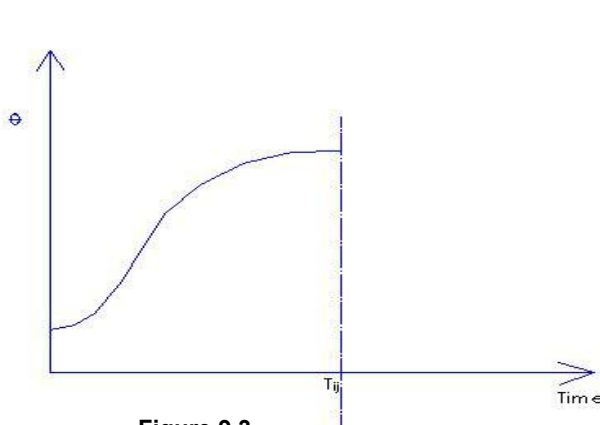

Figure 9.3

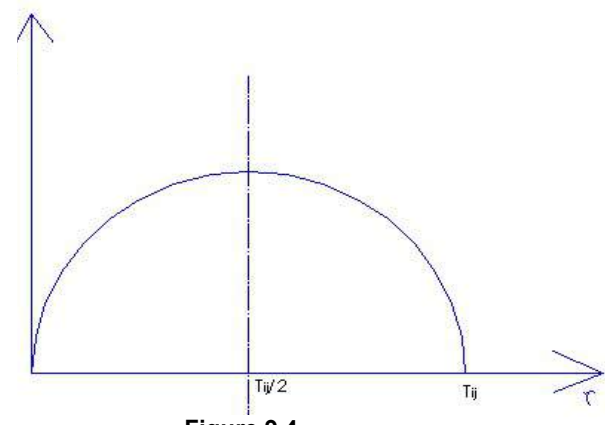

Figure 9.4

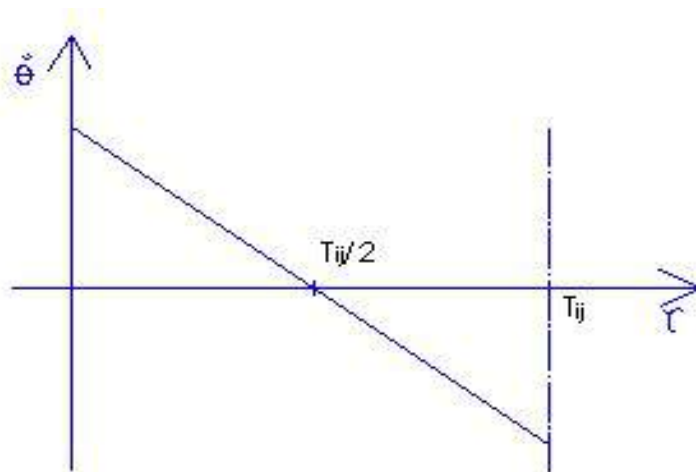

Figure 9.5 (Craig 2005, 204)

Example (1):

A single-link robot with a rotary joint is motionless at  $\theta_i = 15$  degrees. It is desired to move the joint in a smooth manner to  $\theta_j = 75$  degrees in three seconds. Find the coefficients of a cubic that accomplishes this motion and brings the manipulator to rest at the goal. Plot the position, velocity and acceleration of the joint as a function of time.

Plugging into (equation 10), we find that

$$\theta(\tau) = C_0 + C_1 \tau + C_2 \tau^2 + C_3 \tau^3$$

$$C_2 = \frac{3}{t_f^2}(\theta_j - \theta_i) \quad (\text{equation 10})$$

$$C_3 = -\frac{3}{t_f^3}(\theta_j - \theta_i) \quad (\text{equation 11})$$

$$C_0 = 15.0,$$

$$C_1 = 0.0,$$

$$C_2 = 20.0, \quad (\text{By applying equation 11})$$

$$C_3 = -6.66. \quad (\text{By applying equation 12})$$

Using (7.3) and (7.4), we obtain

$$\theta(t) = 15.0 + 20.0t^2 - 6.66t^3, \quad (\text{By applying equation 7})$$

$$\dot{\theta}(t) = 40.0t - 20t^2, \quad (\text{By applying equation 8})$$

$$\ddot{\theta}(t) = 40.0 - 40t. \quad (\text{By applying equation 9})$$

Figure 9.6 shows the position, velocity and acceleration functions for this motion sampled at 40 Hz. Note that the velocity profile for any cubic function is a parabola and that the acceleration profile is linear (Craig 2005, 205).

### Trajectory generation

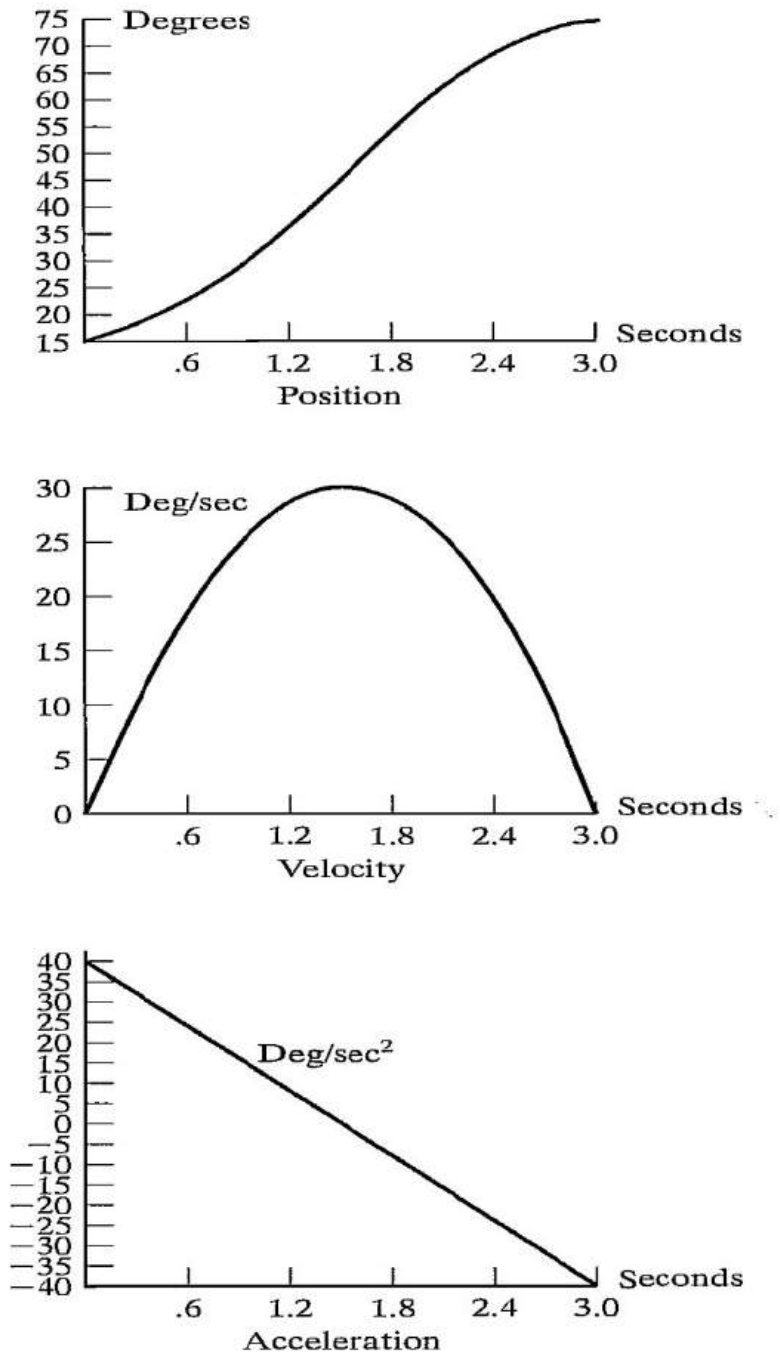

**Figure 9.6**  
(Craig 2005, 206)

## User specify n+2

Final position

Position velocity

User has to give Cartesian data and large data which is kinematically consistent:

Another constraints → user interface must be simple

Task space	↔	Joint space
<u>Initial position</u>		<u>Final position</u>
$\theta_i$		$\theta_j$
$\theta_i'$		$\theta_j'$

'n' via point

- $(n+2)$  position/velocity data

User should specify the following for creating trajectory:

- Initial position
- Final position
- Via points

Notice: Position specifies velocity to be chosen by the system.

### Example:

3 points specified i, j, k

i, k → position /velocity

j → position

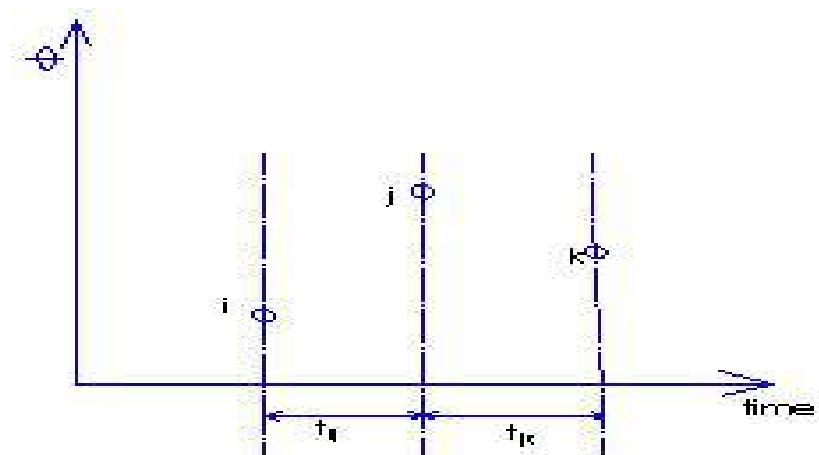

Figure 9.6 this picture specifies time with respect of speed

Two cubic curves (segment)

$i \rightarrow j$	$j \rightarrow k$
$\theta(\tau) = C_0 + C_1 \tau + C_2 \tau^2 + C_3 \tau^3$	$\theta(\tau) = b_0 + b_1 \tau + b_2 \tau^2 + b_3 \tau^3$
$\tau : 0 \rightarrow t_{ij}$	$\tau : 0 \rightarrow t_{jk}$
$\theta(0) = \theta_i$	$\theta(0) = \theta_j$
$\theta'(0) = \theta'_i$	$\theta(t_{jk}) = \theta_k$
$\theta(t_{ij}) = \theta_j$	$\theta'(t_{jk}) = \theta'_k$

at j:

Continuity of velocity and acceleration

$$\theta(\tau) = C_0 + C_1 \tau + C_2 \tau^2 + C_3 \tau^3 \rightarrow ij$$

$$\theta'(\tau) = C_1 + 2C_2 \tau + 3C_3 \tau^2$$

$$\theta''(\tau) = 2C_2 + 6C_3 \tau$$

at jk:

$$\theta(\tau) = b_0 + b_1 \tau + b_2 \tau^2 + b_3 \tau^3 \rightarrow jk$$

$$\theta'(\tau) = b_1 + 2b_2 \tau + 3b_3 \tau^2$$

$$\theta''(\tau) = 2b_2 + 6b_3 \tau$$

Velocity continues at j

$$C_1 + 2C_2 t_{ij} + 3C_3 (t_{ij})^2 = b_1 \text{ (Craig 2005, 208-210.)}$$

$$2C_2 + 6C_3 (t_{ij}) = 2b_2$$

We have 8 equations with 8 coefficients.

**In general we can say:**

Initial position n final position  
 Velocity (via points) velocity  
 n+1 cubic segment to be fit each segment has 4 coefficients  $L_1(n+1)$  coefficients  
 to be determined  
 4(n+1) equations required

Initial position/ velocity	2 equations
Final position/velocity	2 equations

At each via points

Position condition	2 equations
Velocity continuity	1 equations
Acceleration continuity	1 equation
n (via points) →	4 equations

Notice: total number of equations = (4n+1)

All the coefficients can be determined or found (Craig 2005, 201-214.)

## 9.6 Why to use cubic segment?

- Lowest degree polynomial that ensure velocity and acceleration continuity is guaranteed
- Easy to work with
- We can use lower or higher polynomial also.

Move from position  $i$  to  $j$

$posn$	$vel$	$acc$
$\theta_i$	$\theta_i'$	$\theta_i''$
$\theta_j$	$\theta_j'$	$\theta_j''$

We notice that we have six coefficients

Example: pick and place application

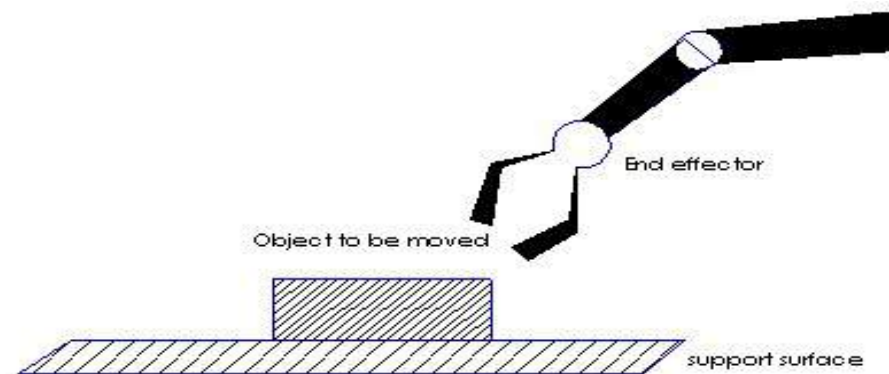

Figure 9.7

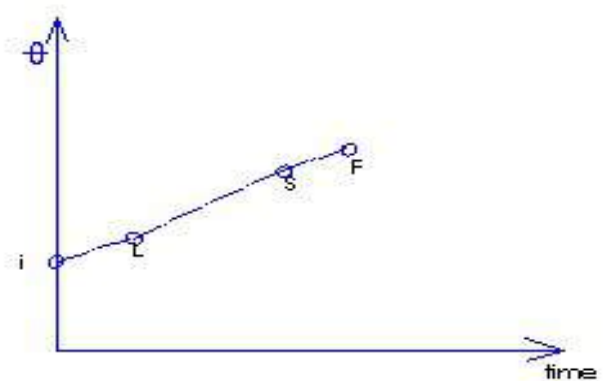

Figure 9.8

**There are three points:**

1. initial position  $\rightarrow (i)$
2. left up position  $\rightarrow (L)$
3. set down position  $\rightarrow (s)$
4. final position  $\rightarrow (j)$

For individual joint:

## 9.7 Common strategy 4-3-4 trajectory:

- $il \rightarrow 4^{\text{th}}$  polynomial degree
- $ls \rightarrow 3^{\text{th}}$  polynomial degree (cubic)
- $sf \rightarrow 4^{\text{th}}$  polynomial degree

### Local time frames $\mathcal{T}$ :

- $il \rightarrow$  the period of  $t_{il}$
- $ls \rightarrow$  the period of  $t_{ls}$
- $sf \rightarrow$  the period of  $t_{sf}$

#### First $\theta_{il}$

$$\theta_{il} = a_0 + a_1\mathcal{T} + a_2\mathcal{T}^2 + a_3\mathcal{T}^3 + a_4\mathcal{T}^4$$

(5 coefficients to be found)

#### Second $\theta_{ls}$

$$\theta_{ls} = b_0 + b_1\mathcal{T} + b_2\mathcal{T}^2 + b_3\mathcal{T}^3$$

(4 coefficients to be found)

#### Third $\theta_{sf}$

$$\theta_{sf} = c_0 + c_1\mathcal{T} + c_2\mathcal{T}^2 + c_3\mathcal{T}^3 + c_4\mathcal{T}^4$$

(5 coefficients to be found)

4 equations is required

#### At $i$ initial point:

$$\theta_{il}(0) = \theta_i \quad (\text{equation 1})$$

$$\theta'_{il}(0) = \theta'_i \quad (\text{equation 2})$$

$$\theta''_{il}(0) = \theta''_i \quad (\text{equation 3})$$

#### At $f$ final point:

$$\theta_{sf}(t_{sf}) = \theta_f \quad (\text{equation 4})$$

$$\theta'_{sf}(t_{sf}) = \theta'_f \quad (\text{equation 5})$$

$$\theta''_{sf}(t_{sf}) = \theta''_f \quad (\text{equation 6})$$

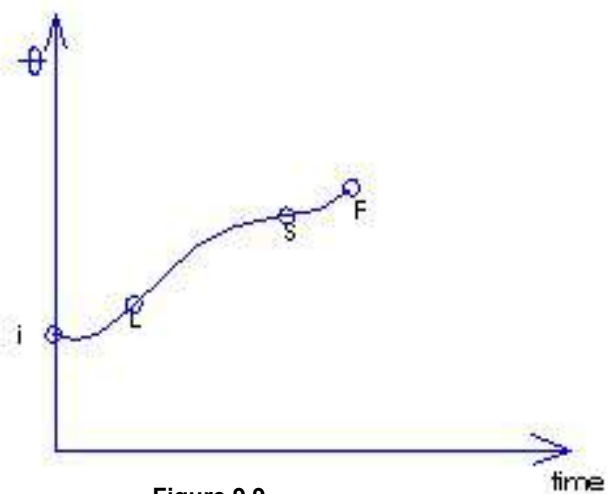

Figure 9.9

At l left up point:

$$\theta_{il}(t_{il}) = \theta_l \quad (\text{equation 7})$$

$$\theta_{ls}(0) = \theta_l \quad (\text{equation 8})$$

$$\theta'_{il}(t_{il}) = \theta'_{ls}(0) \quad (\text{equation 9/ velocity})$$

$$\theta''_{il}(t_{il}) = \theta''_{ls}(0) \quad (\text{equation 10/ acceleration})$$

At s set down point:

$$\theta_{ls}(t_{ls}) = \theta_s \quad (\text{equation 11})$$

$$\theta_{sf}(0) = \theta \quad (\text{equation 12})$$

$$\theta'_{ls}(t_{ls}) = \theta'_{sf}(0) \quad (\text{equation 13/ velocity})$$

$$\theta''_{ls}(t_{ls}) = \theta''_{sf}(0) \quad (\text{equation 14/ acceleration})$$

Notice: all the coefficients of 4-3-4 trajectory can be found.

End effector motion in figure 9.9:

$$\begin{cases} X_B \\ Y_B \end{cases} \leftrightarrow \begin{pmatrix} \theta_1 \\ \theta_2 \end{pmatrix}$$

$X_B$  and  $Y_B$ : are end effector coordinates

$\begin{pmatrix} \theta_1 \\ \theta_2 \end{pmatrix}$ : Kinematic chain

All joints start and stop at the same time.

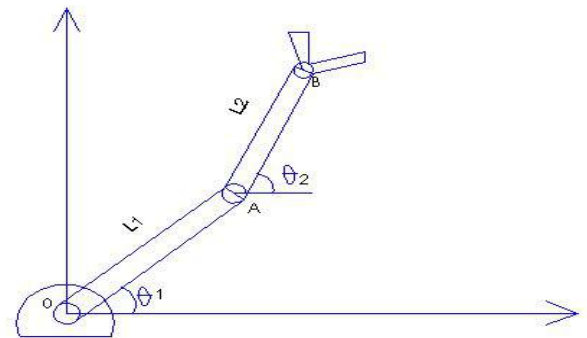

Figure 9.10

## 9.8 Coordinate motion

A given joint  $\theta(T)$

Initial position

via point

final position

$$\theta(T) = c_0 + c_1 T + c_2 T^2 + c_3 T^3$$

Another simple strategy

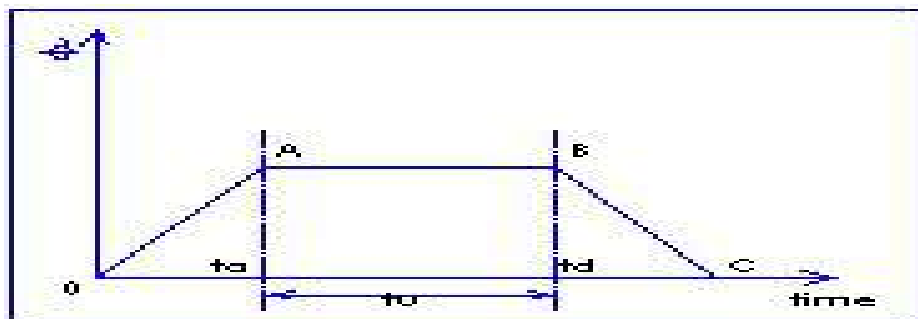

Figure 9.11

Trapezoidal velocity profile

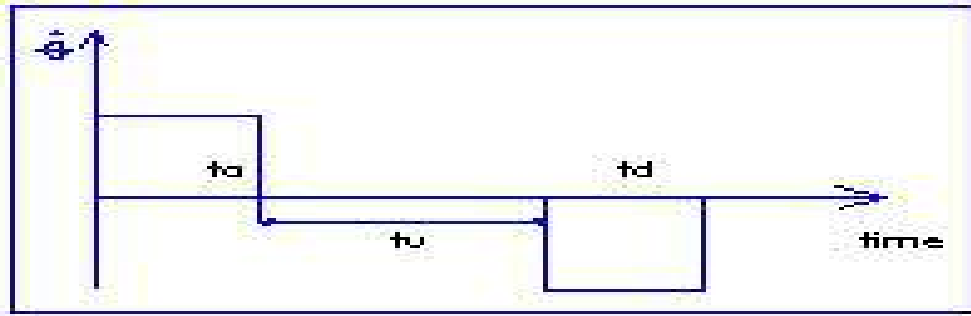

Figure 9.12

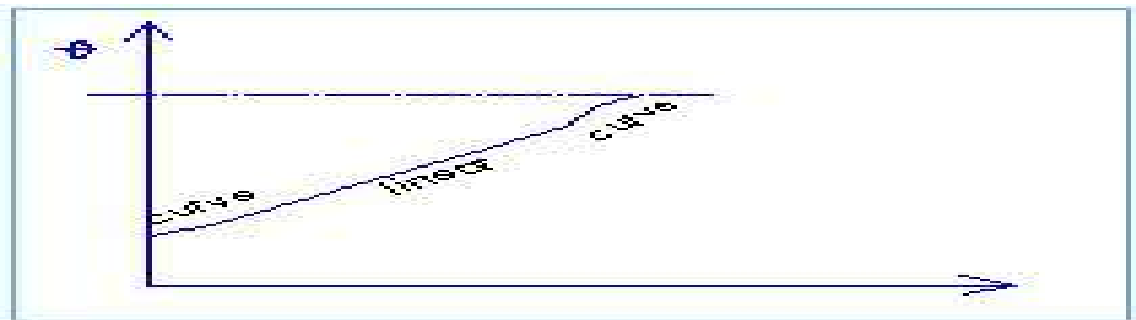

Figure 9.13

$$V = u_0 + at$$

$$S = s_0 + ut + \frac{1}{2}at^2$$

At A

$\theta''$ : ACCELERATION

$t_a$ : Duration

Notice:  $\theta' = \theta''(t_a)$

$$\theta_A = \theta_i + ut + \frac{1}{2}\theta''t^2$$

At B:

$$\theta'_B = \theta'_A = \theta''t_a$$

$$\theta_B = \theta_A + \theta'_A t_u = \theta_i + \frac{1}{2}\theta''t_a^2 + (\theta''t_a)t_u$$

At C : from B to C acceleration  $\theta''$

$$\theta_c = \theta_B + [\theta'_B t_d - \frac{1}{2}\theta''t_d^2]$$

$$= (\theta_i + \frac{1}{2}\theta''t_a^2 + \theta''t_a t_u) + (\theta''t_a t_d - \frac{1}{2}\theta''t_d^2)$$

Let

$$t_u = t_d$$

T = total time

Given  $\theta_i, \theta_f, \theta_i, T$

$$\theta''t_a^2 - \theta''t_a T + (\theta_f - \theta_i) = 0$$

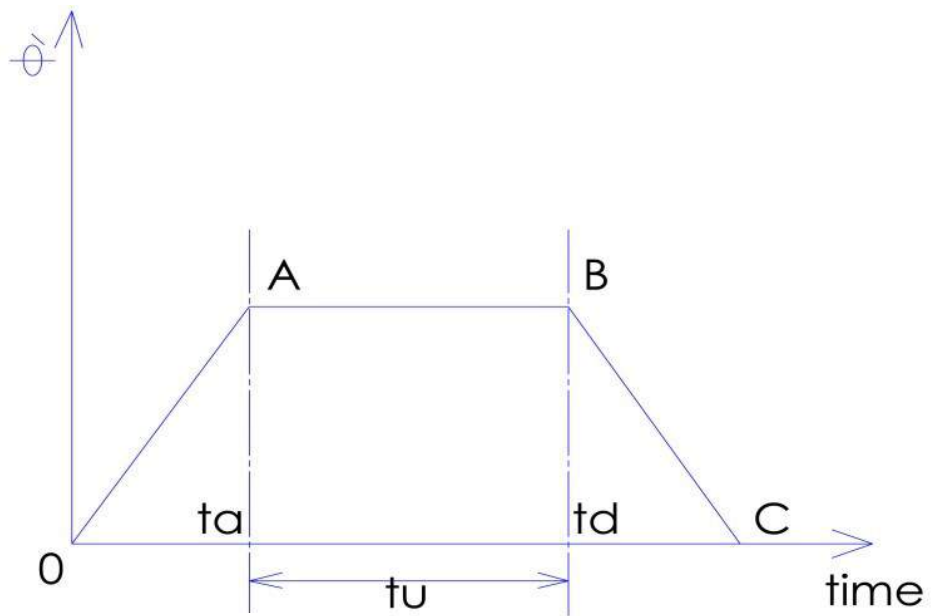

Figure 9.14

(Craig 2005, 210-215).

## 10 Attachment 1

### 1 TRAJECTORY PLANNING BY USING ROBOT STUDIO

#### 1.1 Introduction

In this section I will try to give brief introduction about how we can create path using robot studio through using simulation and virtual flex pendant since they are two different ways, so I will try to explain each way separately beside give introduction about how we can choose from ABB Library geometry and tools and how we can set their position in robot environment.

#### 1.2 Creating new station and saving it

First we need to choose any robot type by clicking *ABB library* (watch picture 1).

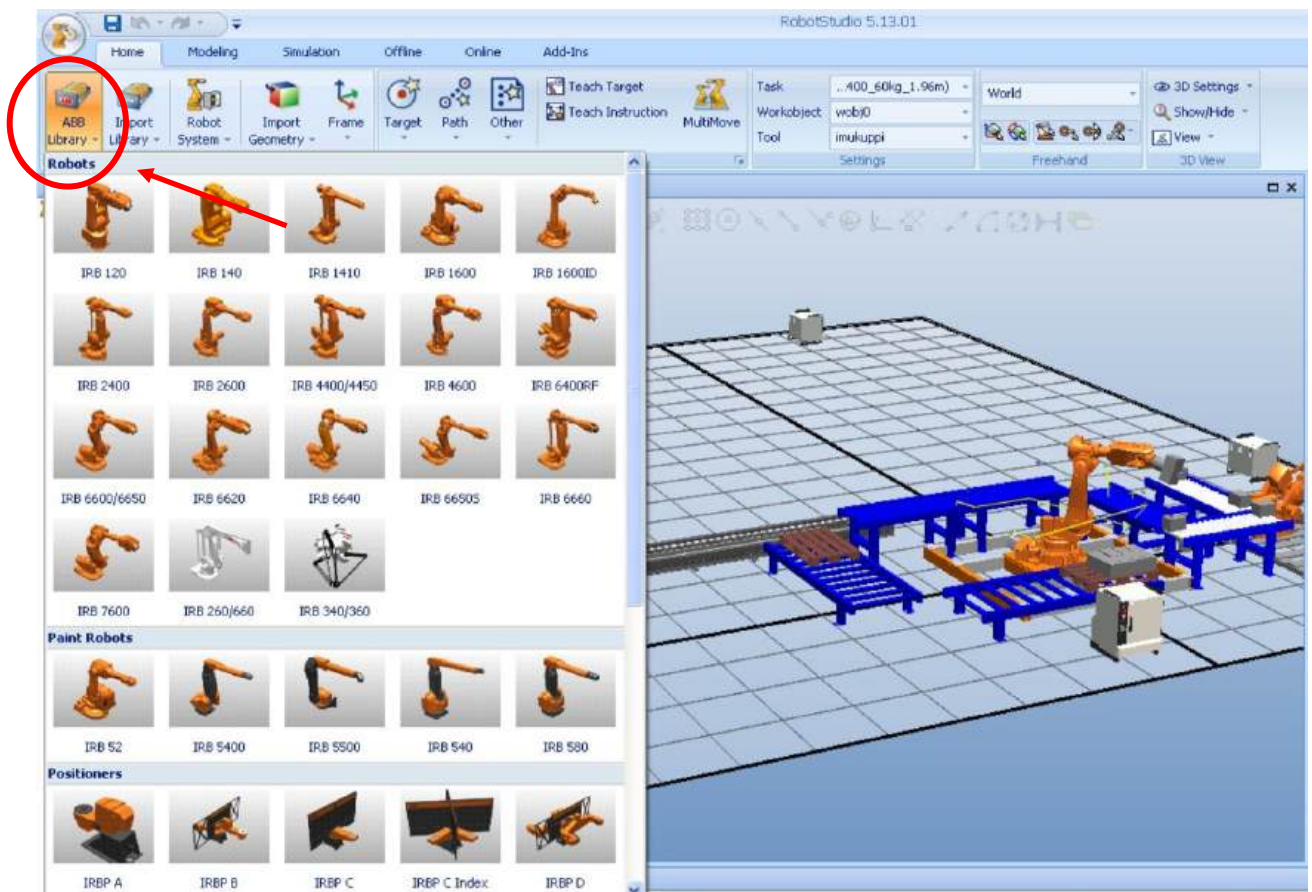

Picture 1 (robot studio screenshot)

How to open new station and to choose robot from ABB library

Select the Icon **import library** then select **equipment** then you go down and select any tool by clicking any tool for example I will choose any end effector tool from the library (watch picture 2).

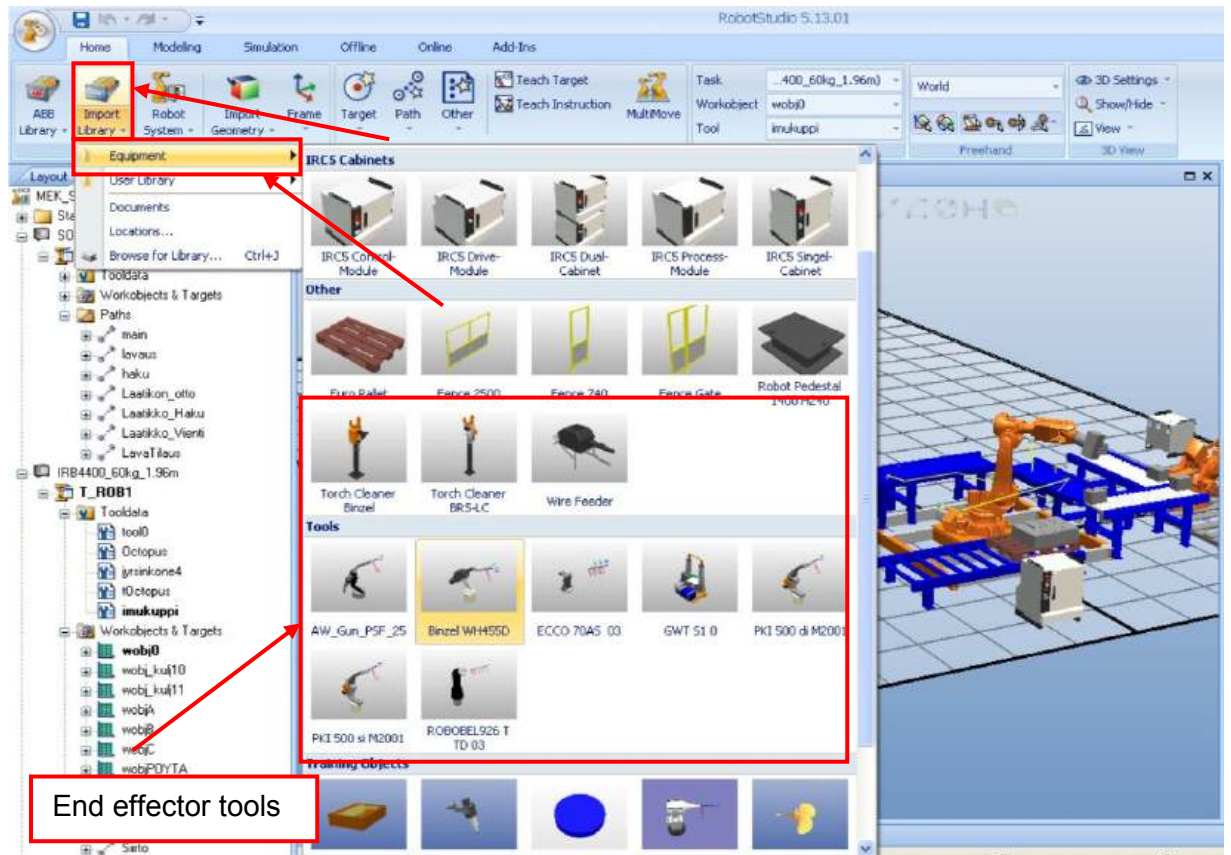

**Picture 2 (robot studio screenshot)**

How to select from ABB library end effector tool and some other geometry

Then on the left tree you will see the tool name but it is not connected to robot's end effector on the right window, so by dragging the tool name (**PKI 500 di M2001**) and drop it to your (**IRB1600ID 4 5 150 03**) robot then new window will open to ask you (**do you want to keep the current position of the tool**) then you should choose **no** then the tool will be connected to the end effector of the robot (watch picture 3).

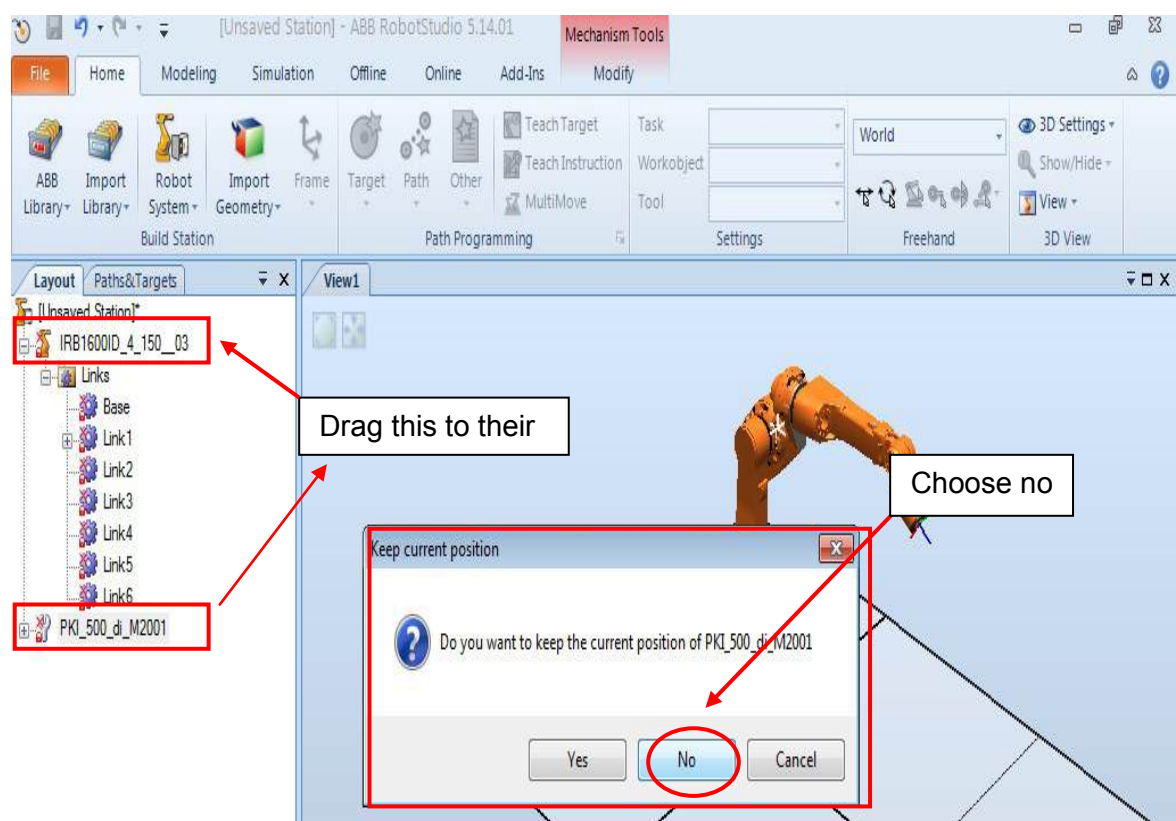

Picture3 (robot studio screenshot)  
Example to explain how to connect end effector to the robot

Now you need to select geometry or table, you need to click on ***import library*** then ***Equipment*** follow the arrow and choose any table by clicking the object then it will appear on red on the robot environment (watch picture 4).

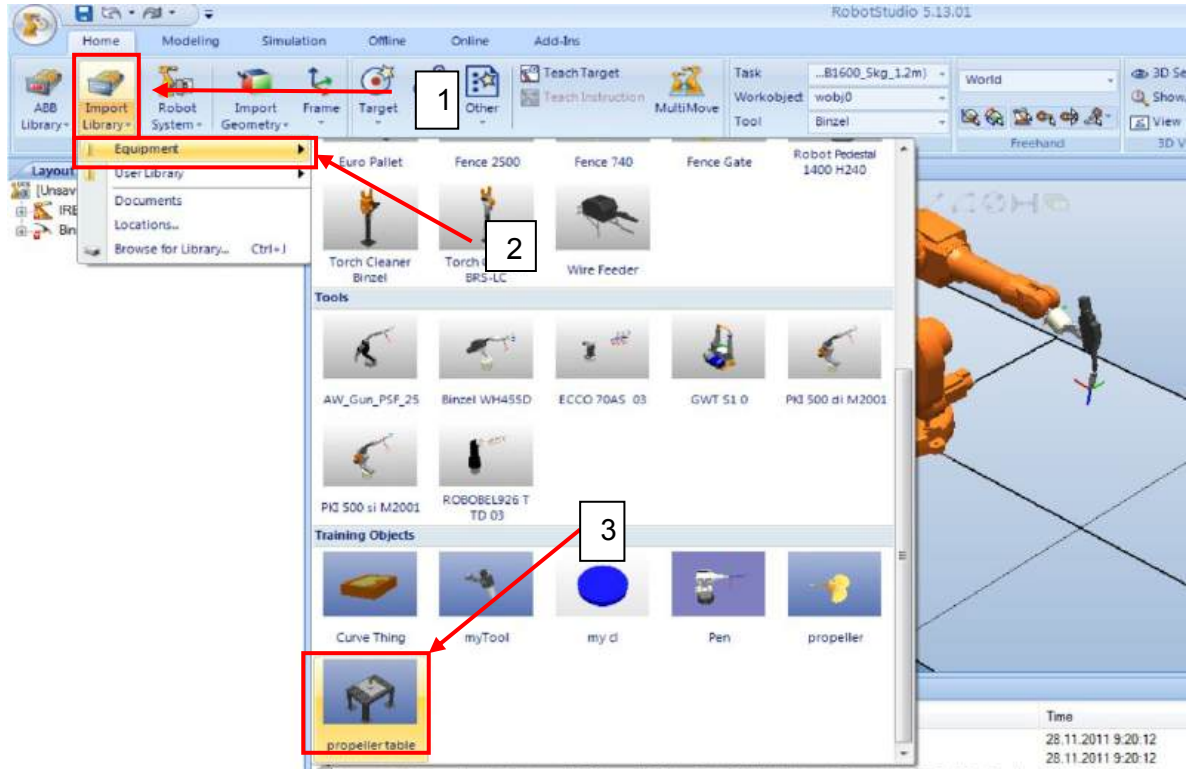

**Picture 4 (robot studio screenshot)**  
How to select table or some other geometry from ABB library

We need to change the position of the table by clicking from home section move order from freehand group button the will appear x and y cross line and we can move by dragging the arrow head right or left and up and down but this way is not precise and I don't recommend to use it.

To get precise position to your geometry look up on the program you will see highlighted button name ***part tools*** and under it there is ***modify*** button, click modify button so new tool bar will open then search the button ***set position*** and after that you can choose any coordinate you need for your table position after that you need to click apply to activate changes (watch Picture 5).

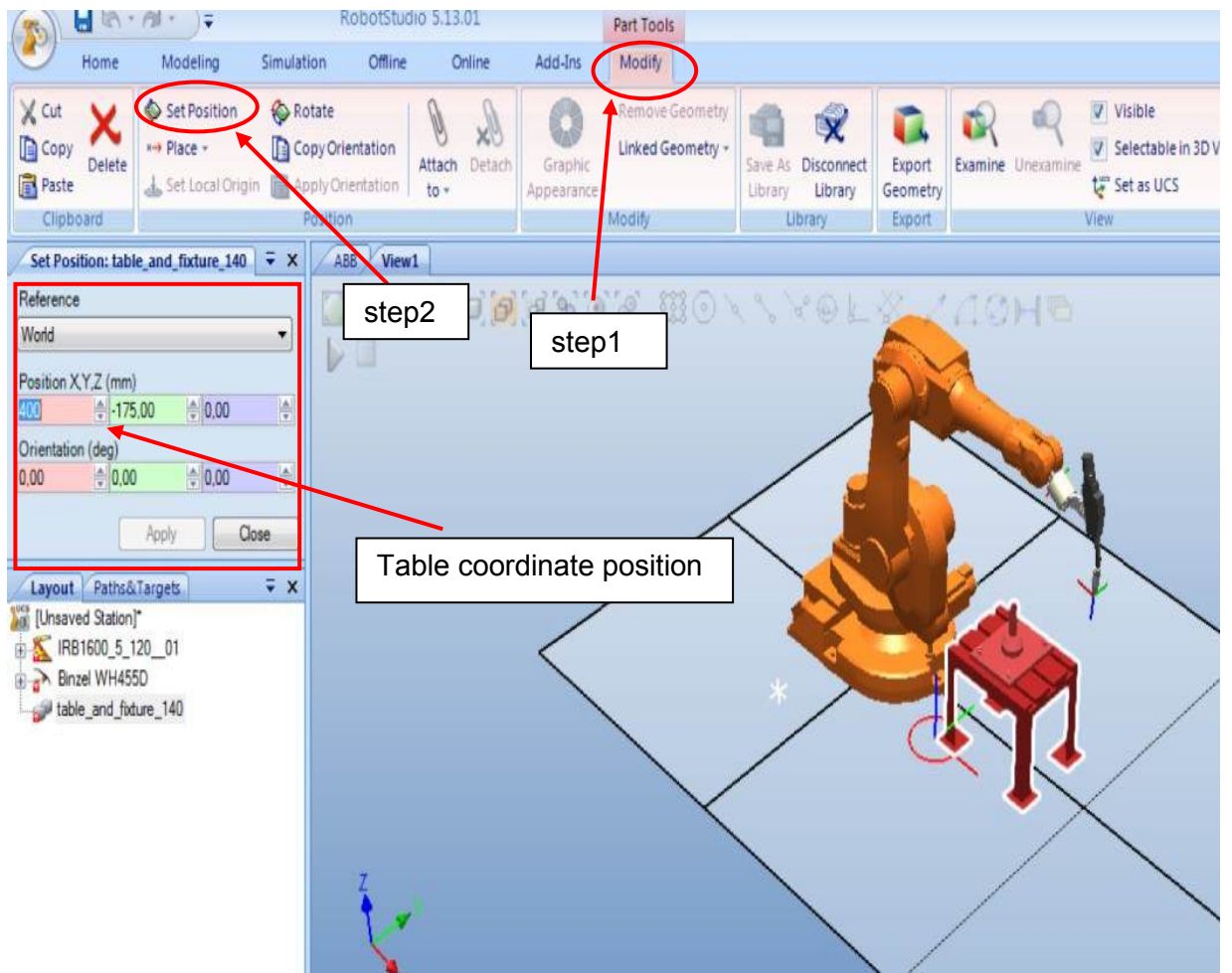

**Picture 5 (robot studio screenshot)**  
**How to change the coordinate of the table position through set position icon**

Now you need to save the station by clicking up in the left side corner by selecting save as then new window will open to rename your station and to select where to save your station.

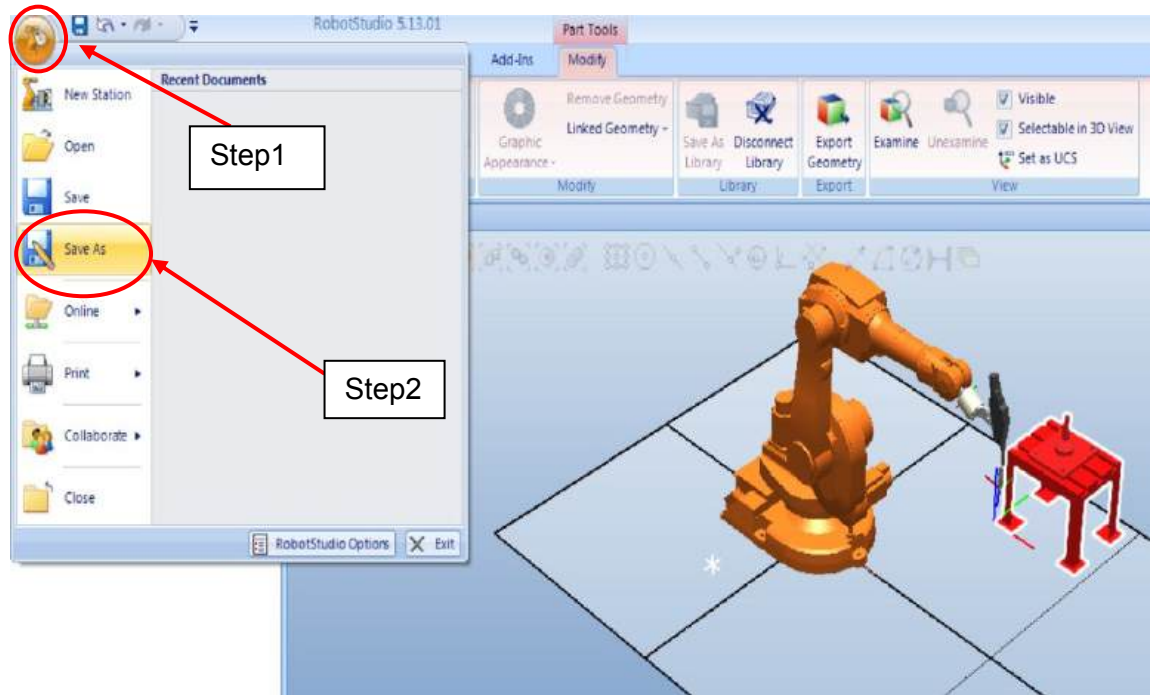

**Picture 6 (robot studio screenshot)**  
How to save new station

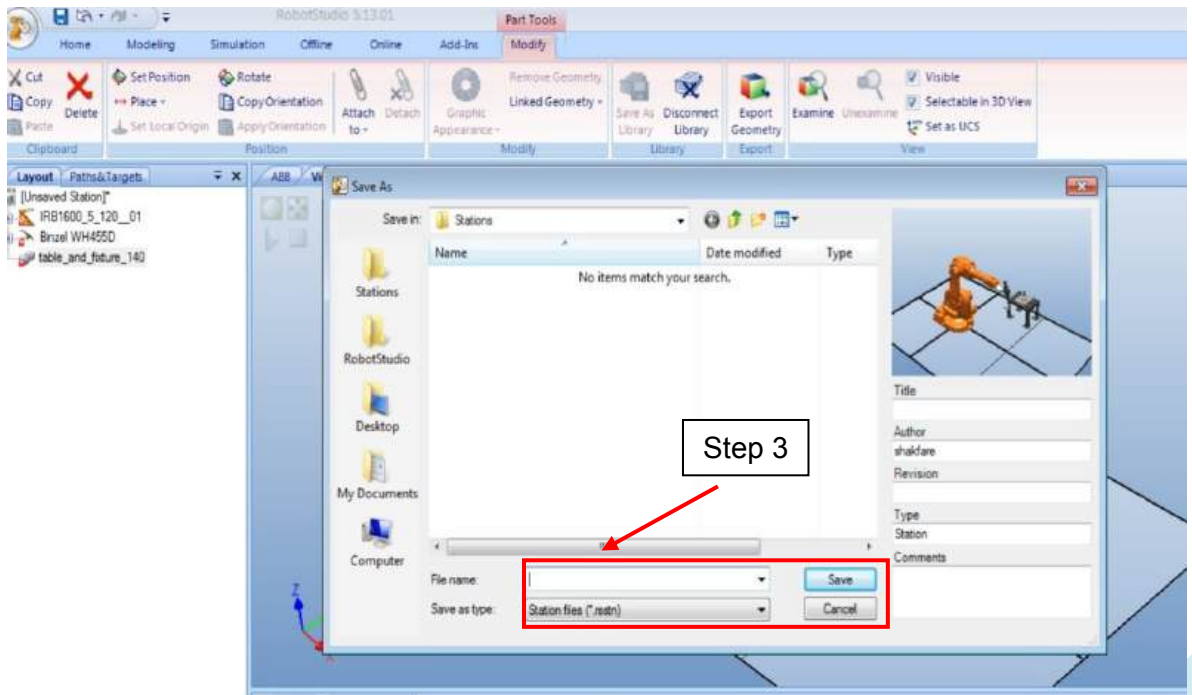

**Picture 7 (robot studio screenshot)**  
Giving a name the station and to choose location on the computer to save it.

### 1.3 Moving robot joint space

Firstly we make right click on the robot tree on the left side on **layout section** then we have several options and from these options we have **jump home** which return robot to default position but you need to focus also on using **mechanism joint jog** and **mechanism linear jog** beside the **free hand** option.

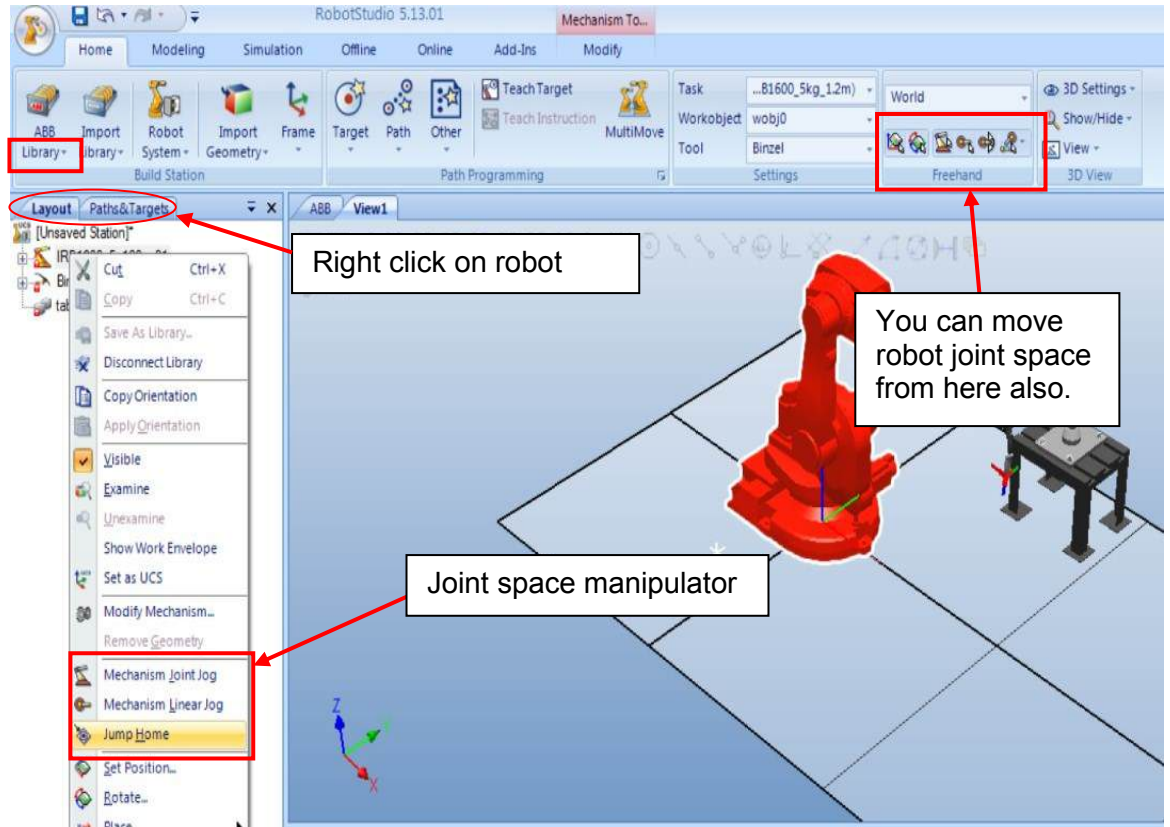

Picture 8 (robot studio screenshot)

Right click on IRB robot so we get the option we need

When you click on maechanism joint jog then it will open new window which look like picture 9. We have 6 joints with six coordinaate to manipulate so we can choose the degree by moving the slide button left and right on the tree section. First joint move robot left and right, second joint move robot up and down, third joint up and down as well, the last three joint move end effector up and down beside left and right.

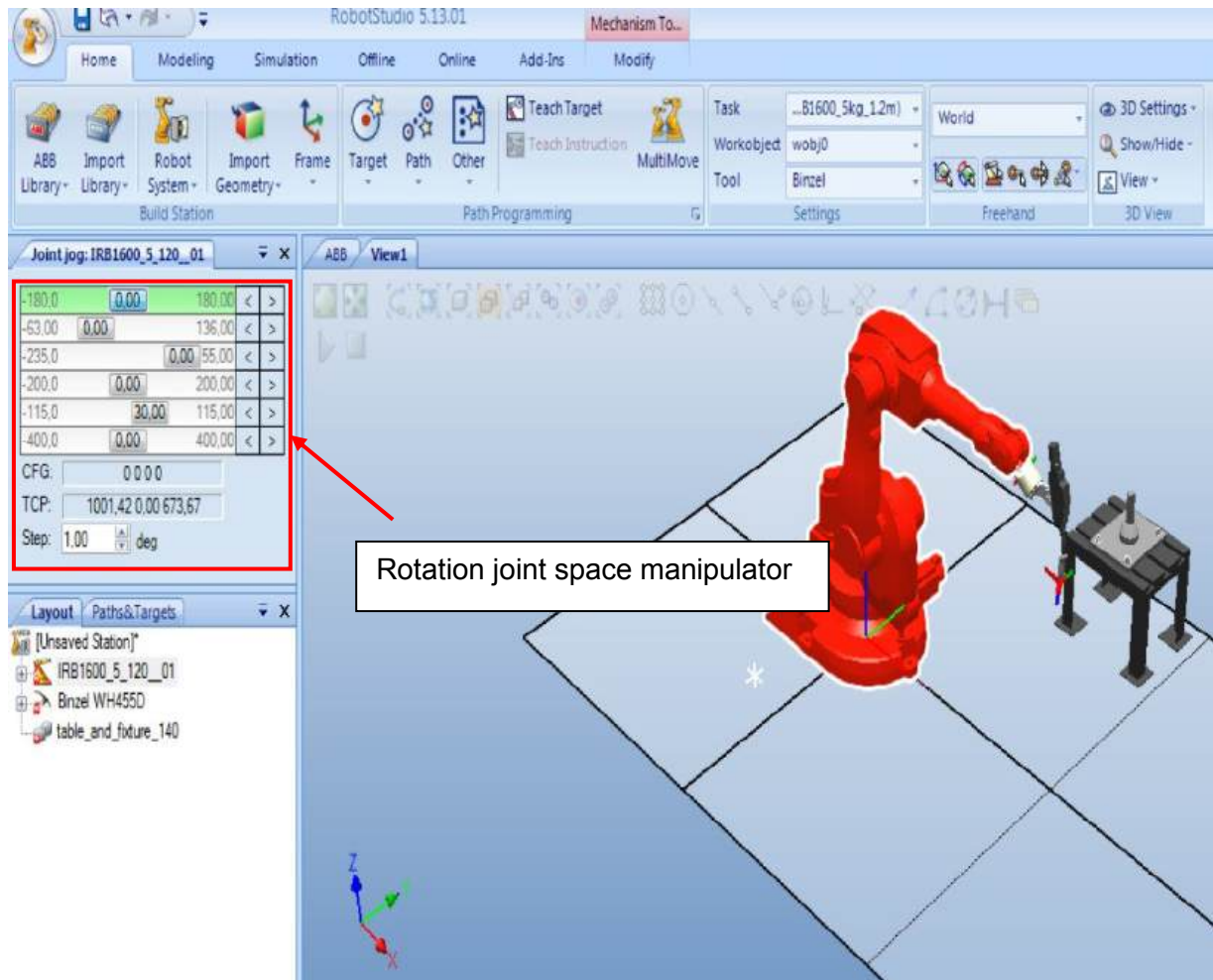

**Picture 9 (robot studio screenshot)**

This picture shows how to change the rotation of each joint in the robot

When you choose ***mechanism linear jog*** then it will appear new window like in picture10 the same way like previous step by moving the slide button left and right we change the coordinate of each joint until we get the desired position. First joint move forward and backward, second joint move right and left with linear motion, third joint move up and down with linear motion, the last three joint move the same like first three but by steps.

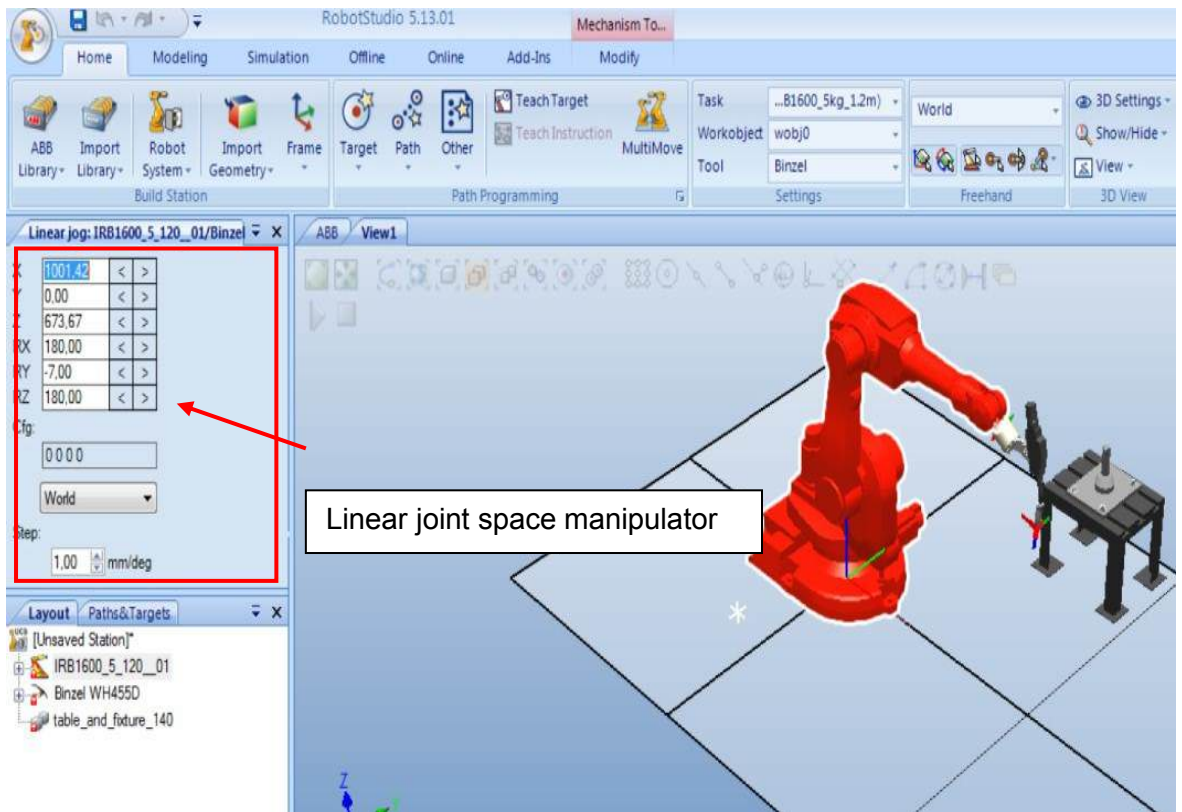

**Picture 10 (robot studio screenshot)**

This picture shows how to change the linear coordinate of each joint

## 1.4 Target teach method

There are two different ways, the first one by using Target teach Icon and the second one is by using Virtual flex pendant, by choosing teach Target you can create path easier than virtual flex pendant but I will try to give small introduction on both ways and the user has the choice to choose the suitable way for creating the path. First we right click the robot from home → layout then we jump home like we mentioned in the previous tutorial, then we clicks on mechanism joint jog and we move the robot joint space (watch picture11).

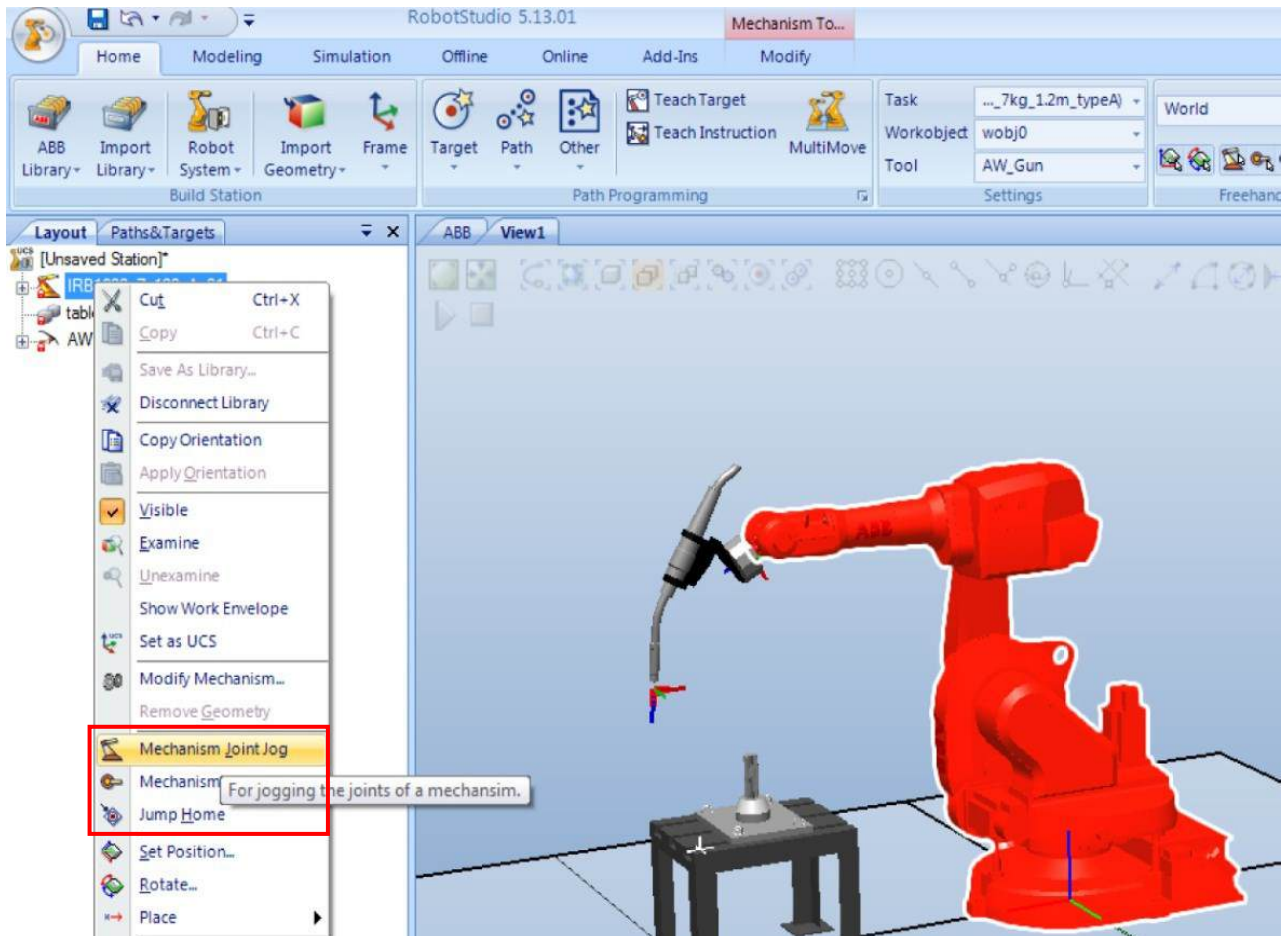

Picture 11 (robot studio screenshot)  
Robot movement options

Move the robot joint the first desired motion the go up on the icon **target** in **home** section then we choose **create target** icon then it will open new window like in picture12.

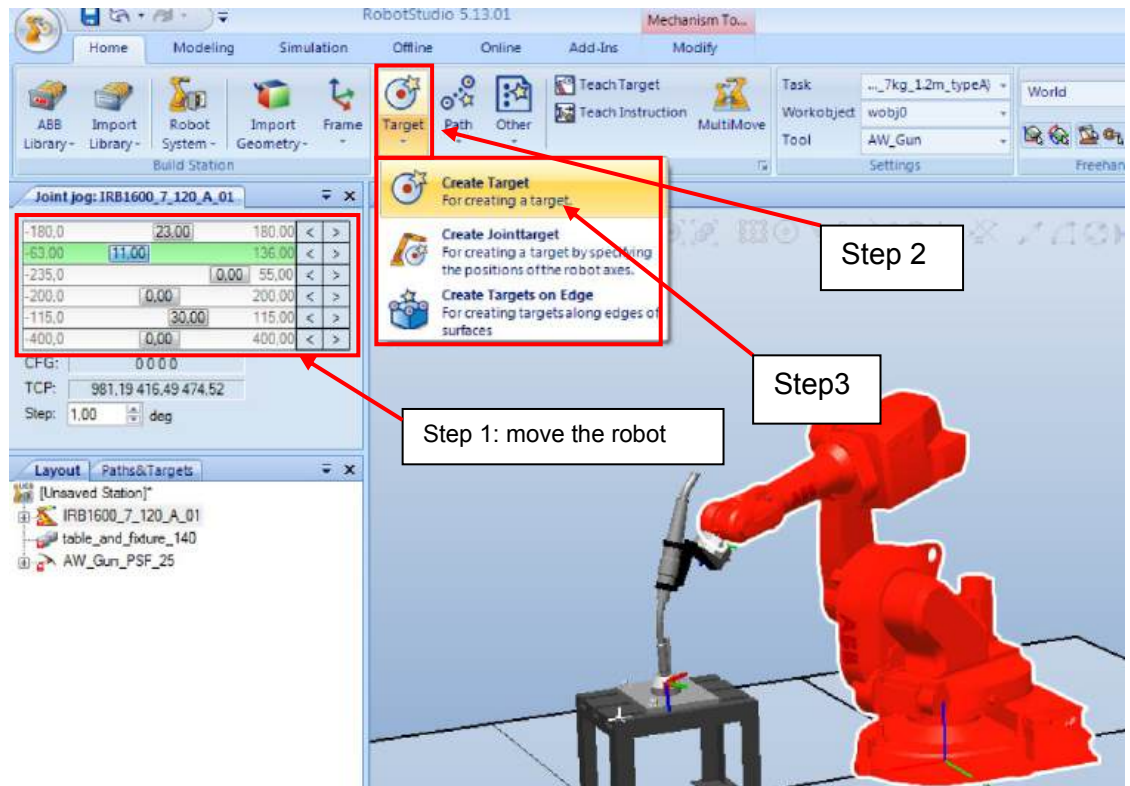

**Picture 11 (robot studio screenshot)**  
How to create path by choosing Target

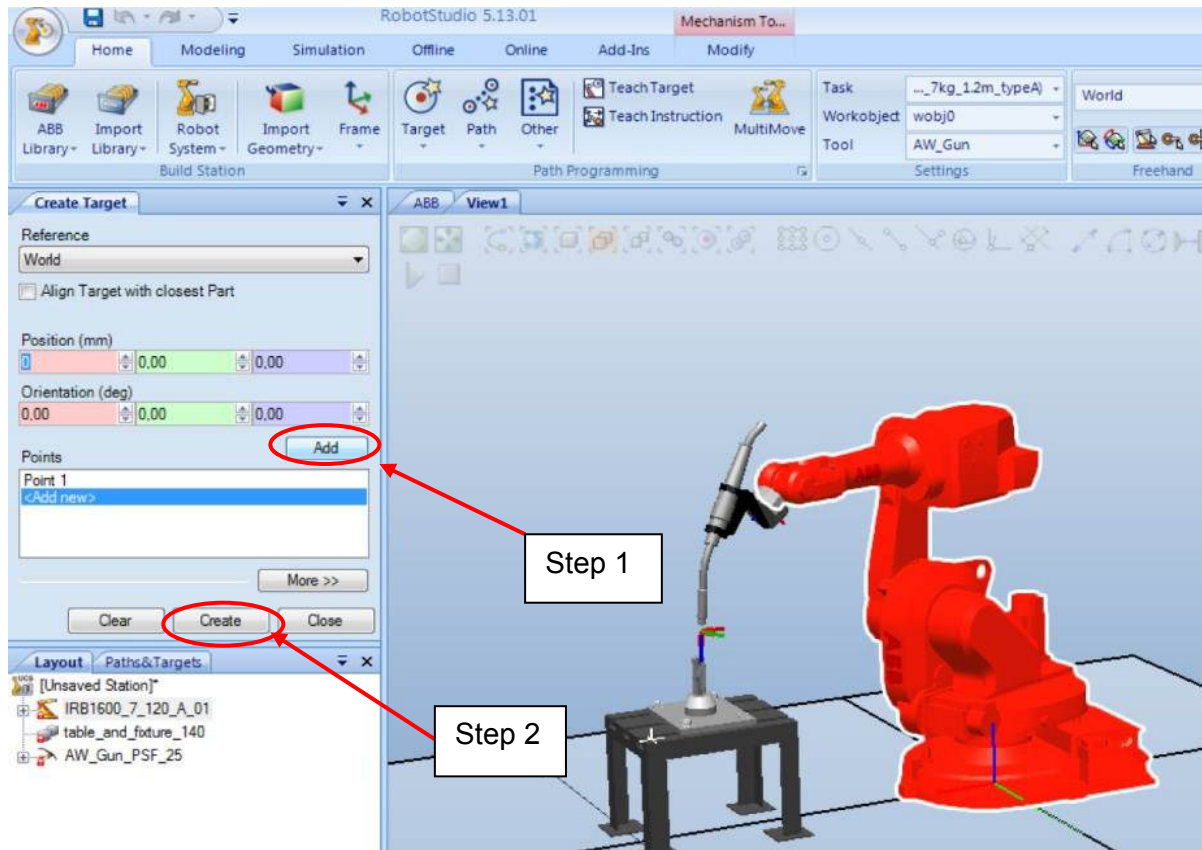

Picture 12 (robot studio screenshot)  
How to create path by choosing Target

We go back to first step to repeat the same process again by right click the robot from **home** → **layout** then we click on **mechanism joint jog** or **linear joint jog** like we mentioned in the previous tutorial.

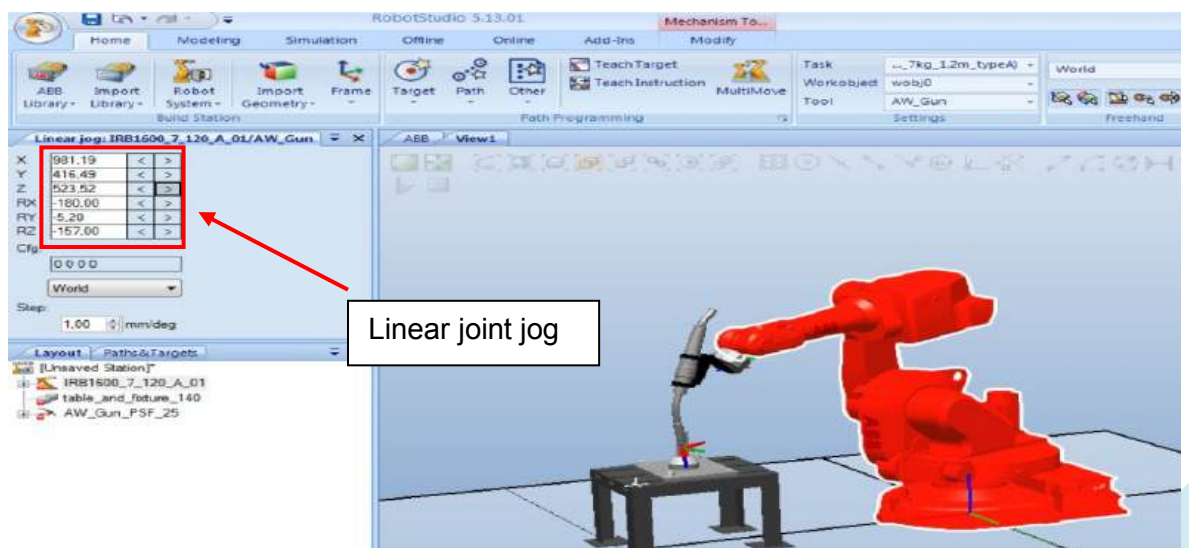

Picture 13 (robot studio screenshot)  
Moving linear joint

Repeat step3 by clicking **create target** then add new point after that go down and choose **create** , then the previous move you have done is saved by the system. We repeat the same again and again until the path point is completely created. When we open the tree of **IRB** on the left in **paths & targets** section we will see that we have **target 10, target 20, target 30, .....target n**. Now we create an empty path then we drag targets to the new path (watch picture 15).

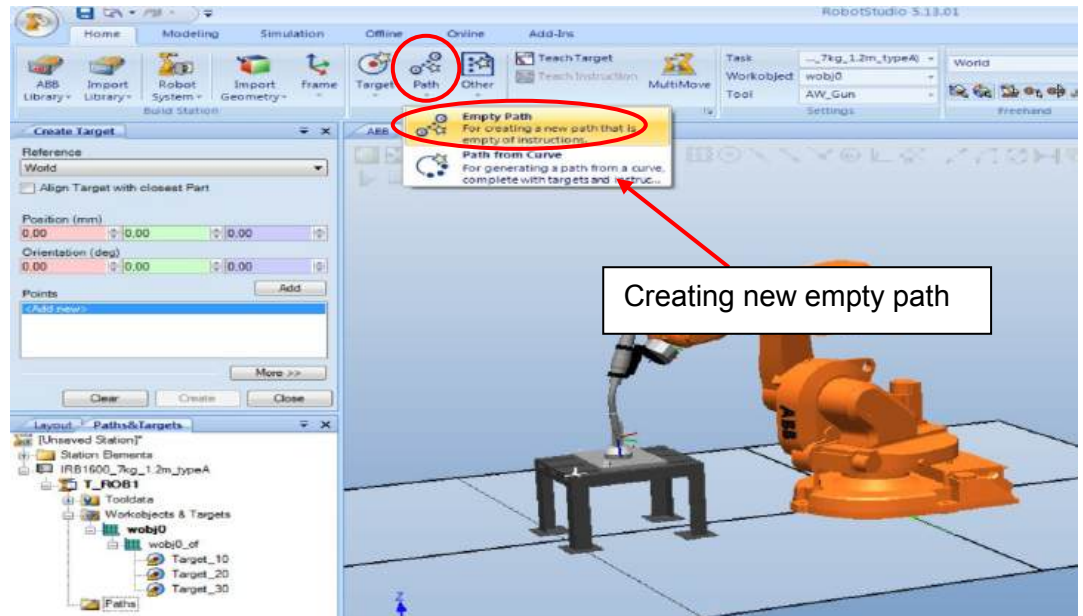

Picture 14 (robot studio screenshot)  
Creating empty path

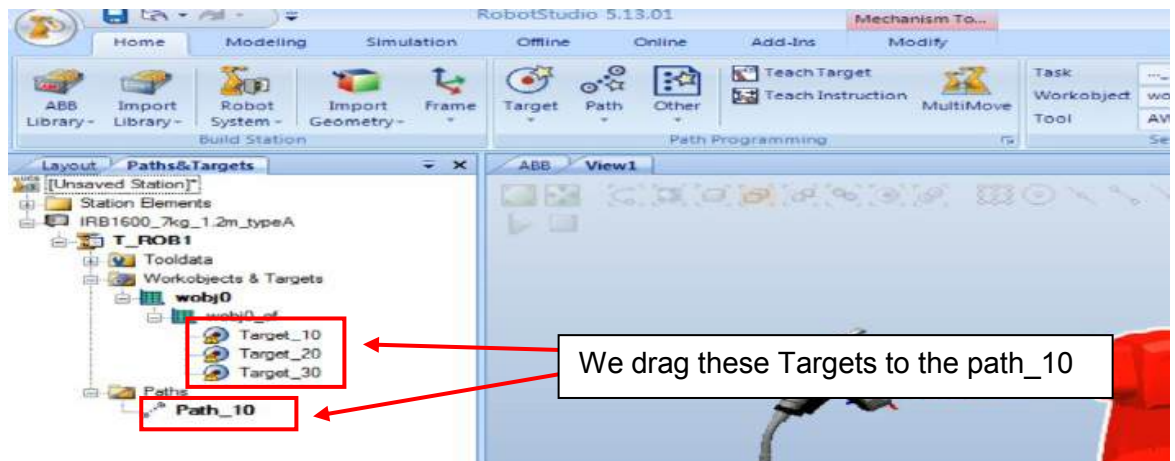

Picture 15 (robot studio screenshot)  
Dragging Targets to the path

Up we will see path tools and modify button under it. Select modify button and new list up will open, search the icon move along path and the robot will debug for few second and robot should move according to the trajectory which is planned or created.

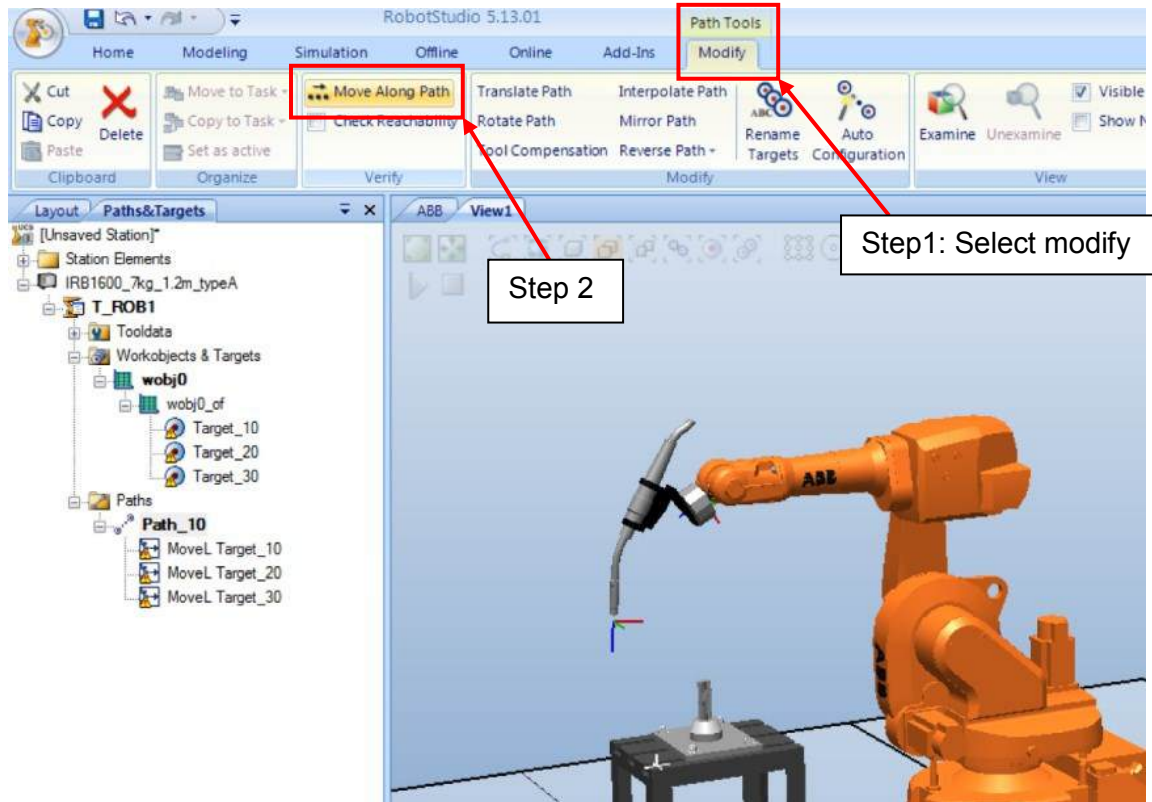

Picture 16 (robot studio screenshot)  
Robot simulation

## 1.5 Create program using virtual flex pendant

First click on offline button then click virtual flexes pendant then ABB on the corner of the new window

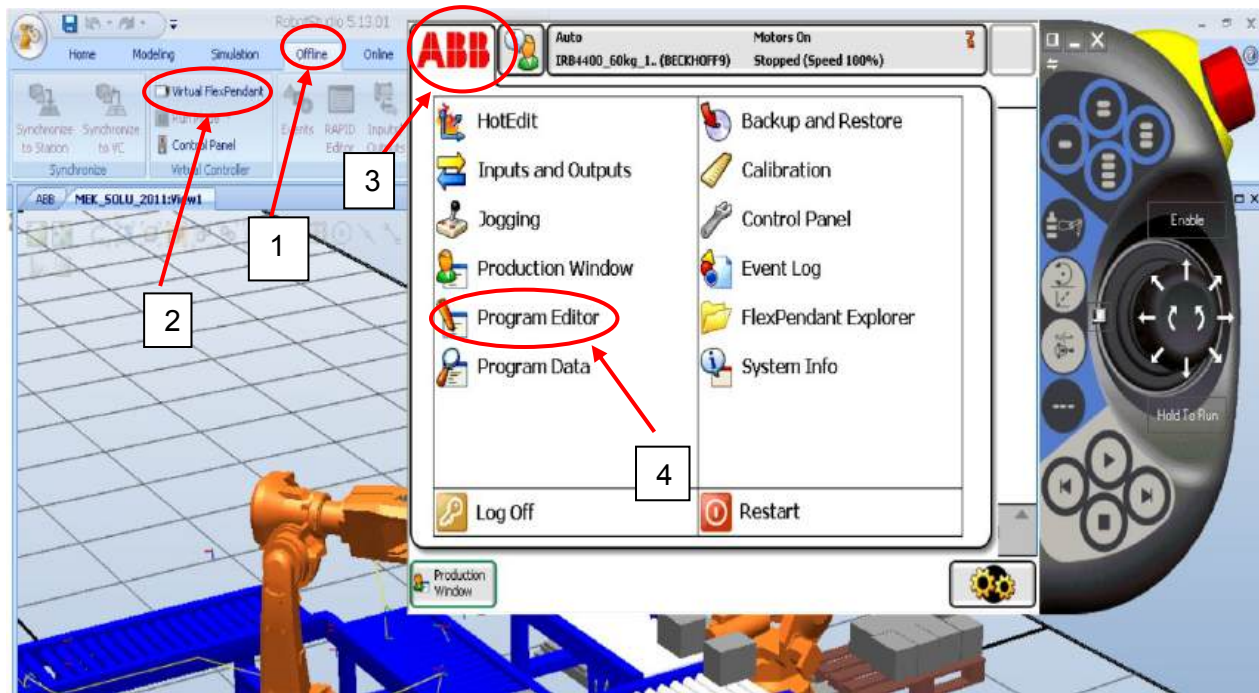

Picture 17 (robot studio screenshot)

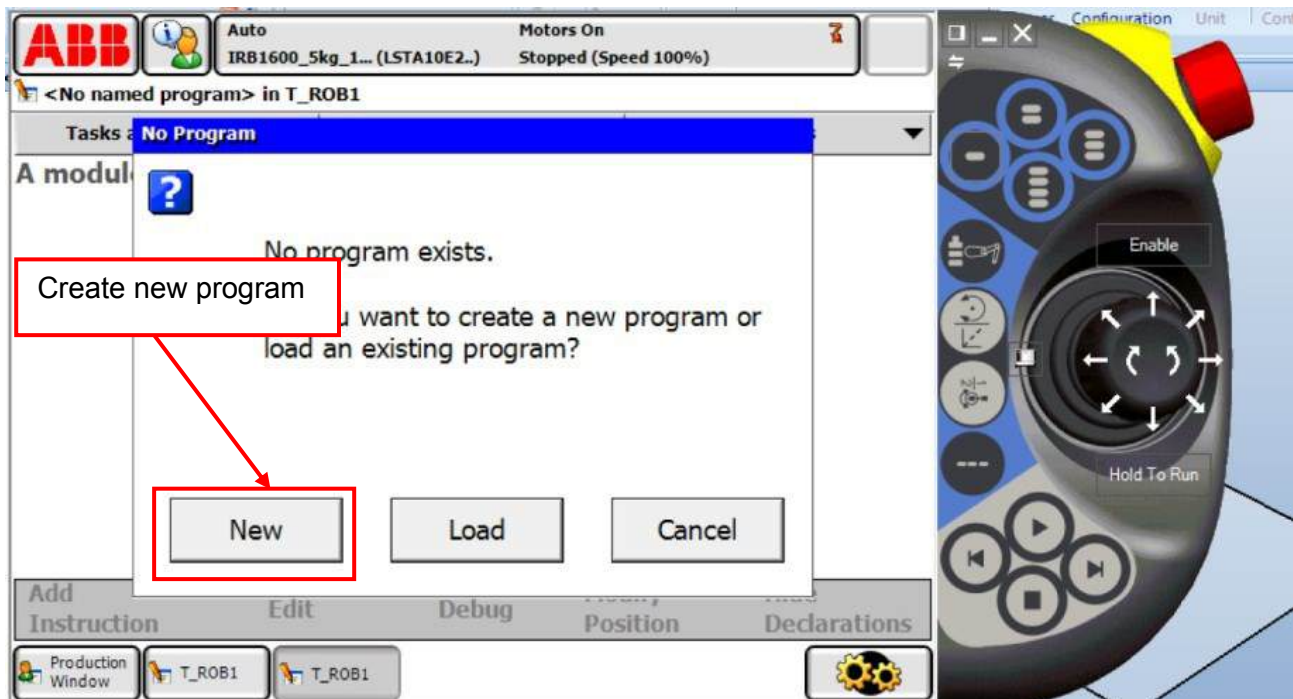

Picture 18 (robot studio screenshot)

We click on save program as and we save new program and we name as well.

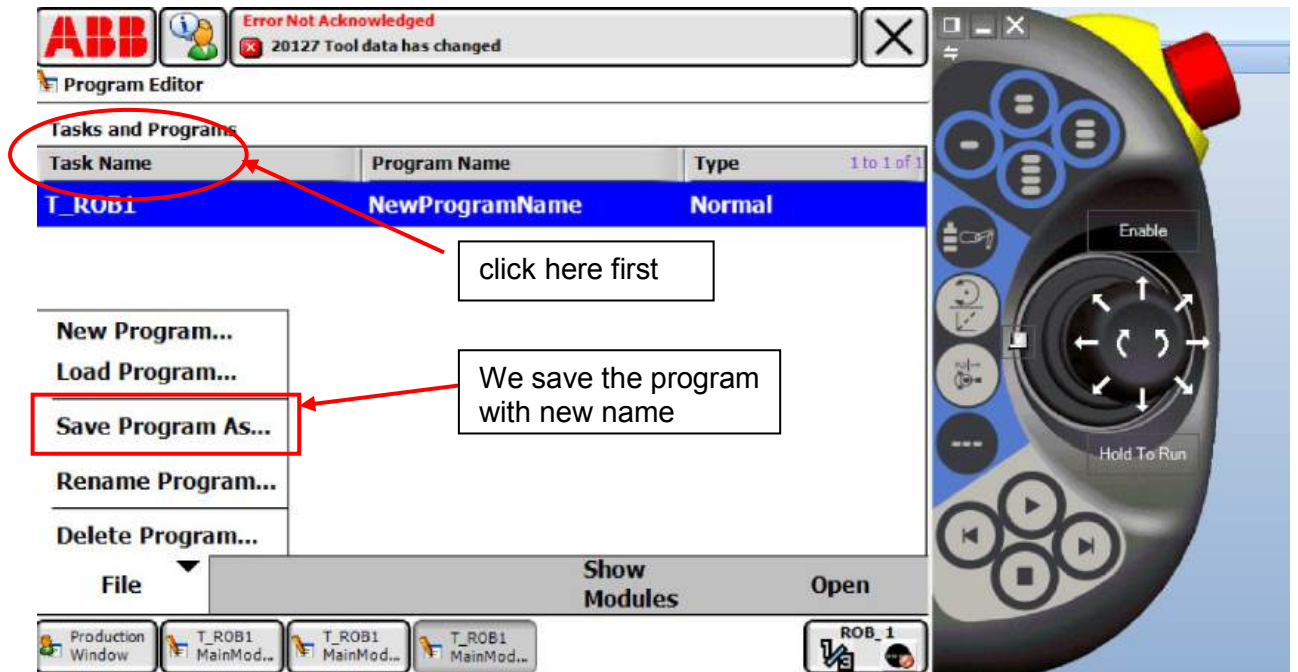

Picture 19 (robot studio screenshot)

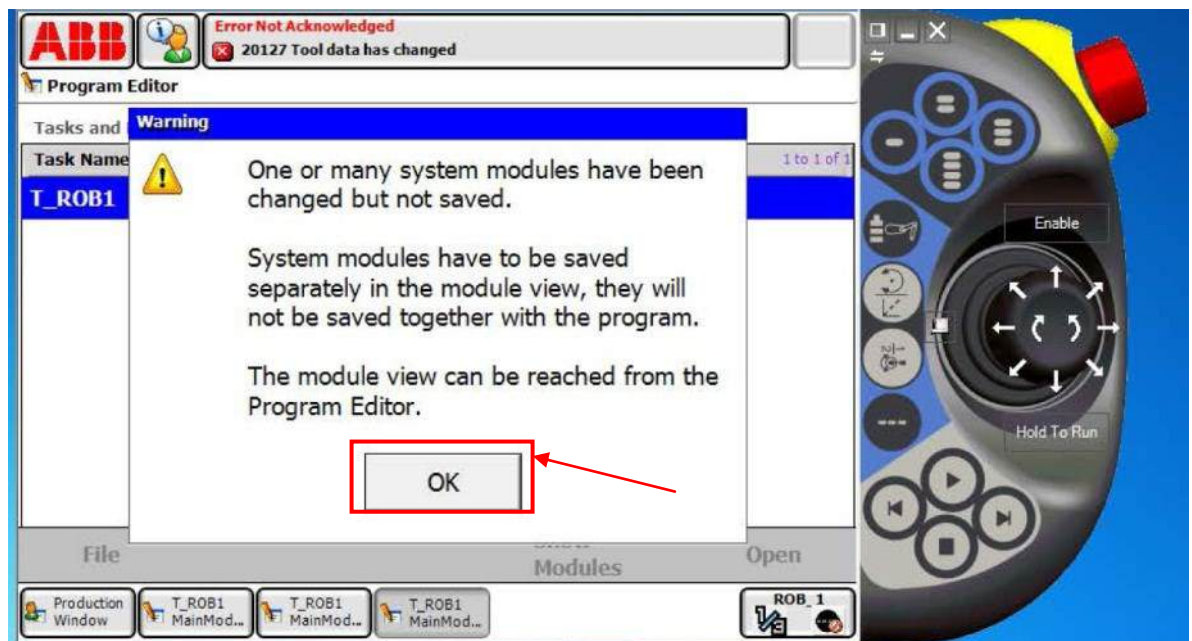

Picture 20 (robot studio screenshot)

Give the file name or select certain file in your hard disk then press ok

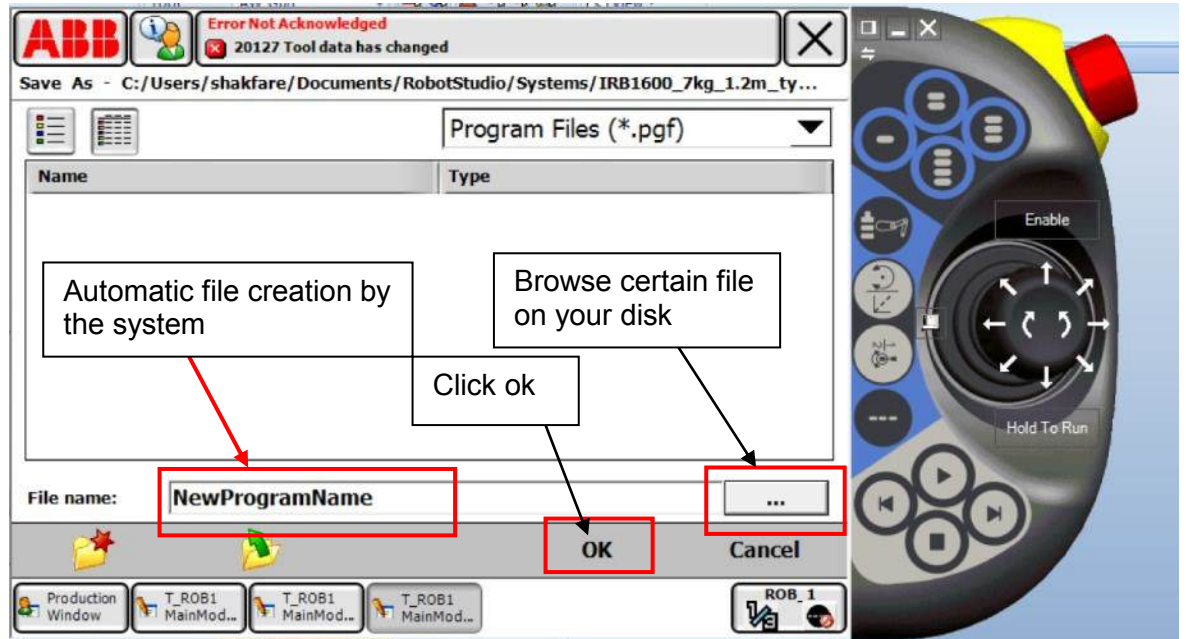

Picture 21 (robot studio screenshot)

Then you give a name to your file which has pgf format

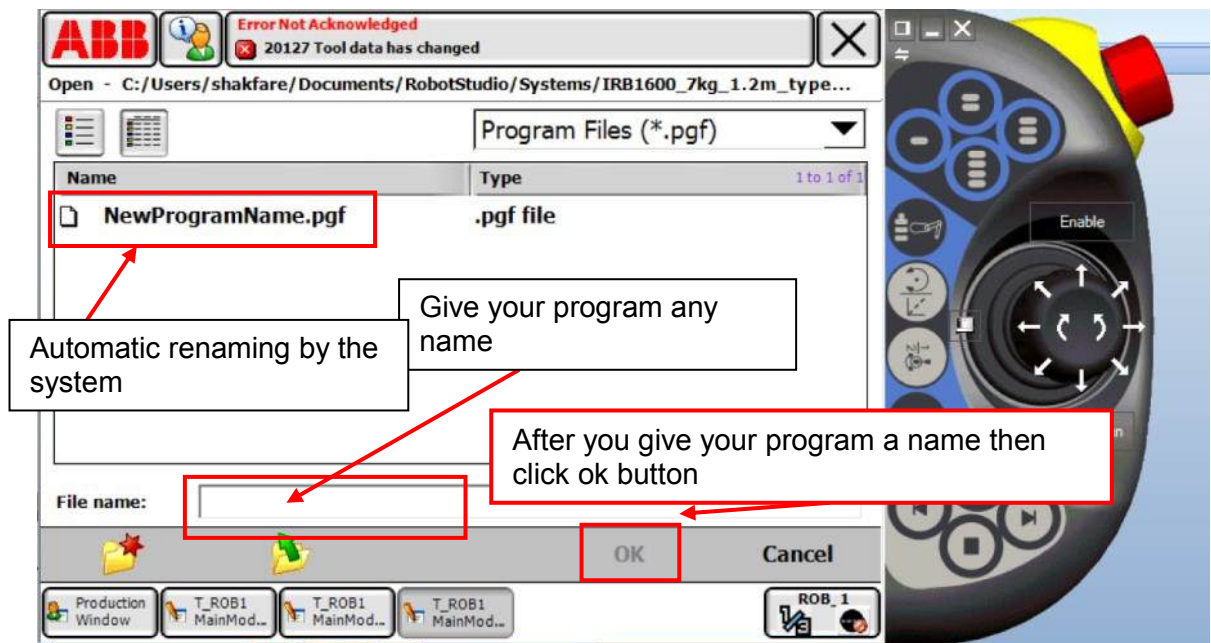

Picture 22 (robot studio screenshot)

Click on load program.

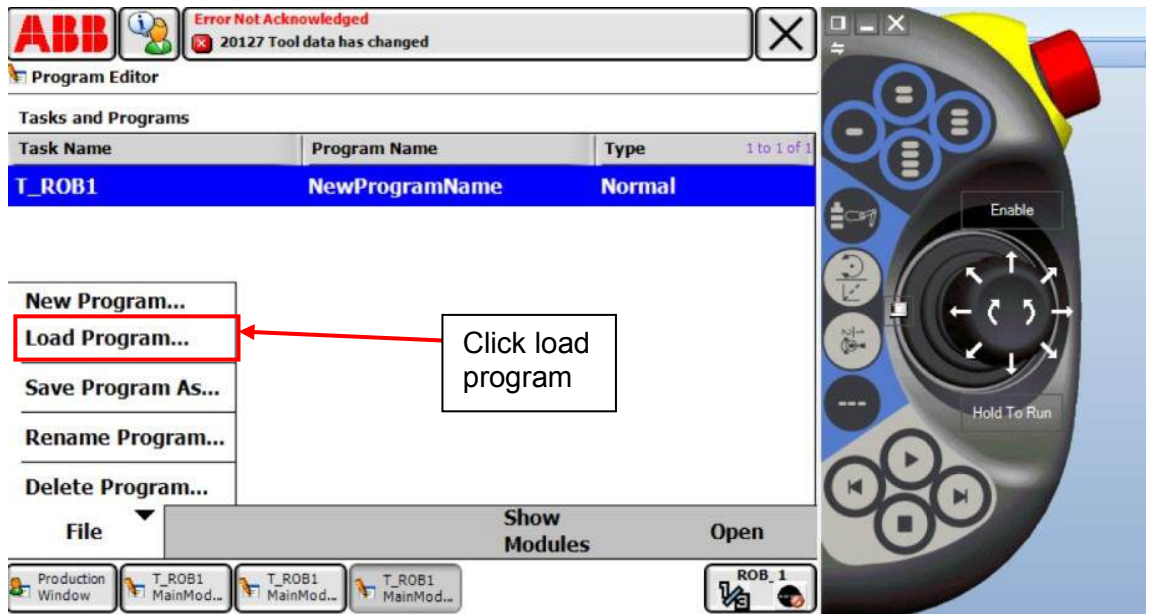

Picture 23 (robot studio screenshot)

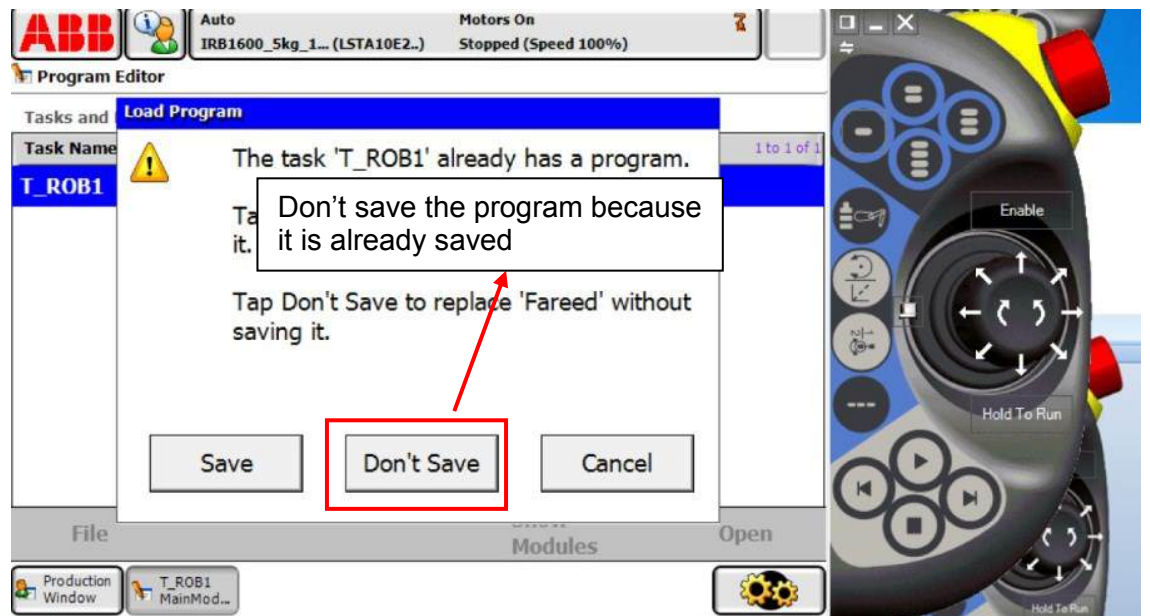

Picture 24 (robot studio screenshot)

We click on **File** and choose **New routine.**

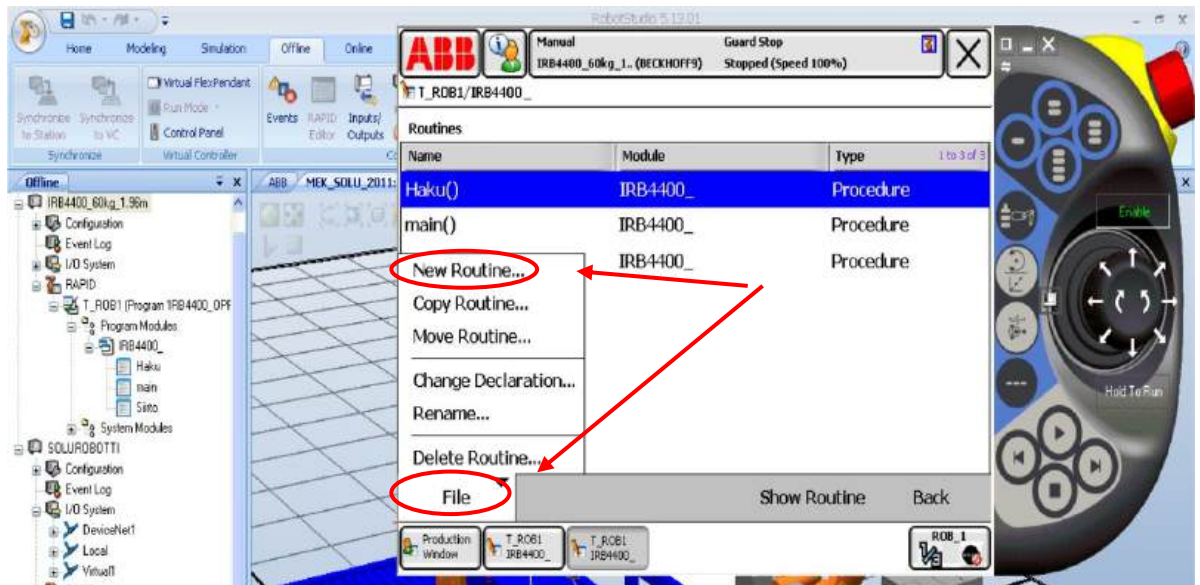

Picture 25 (robot studio screenshot)

Notice: If **New Routine** is not possible to select and the color is gray then check if the motor is on or off and click also on enable button to activate and should be in green.

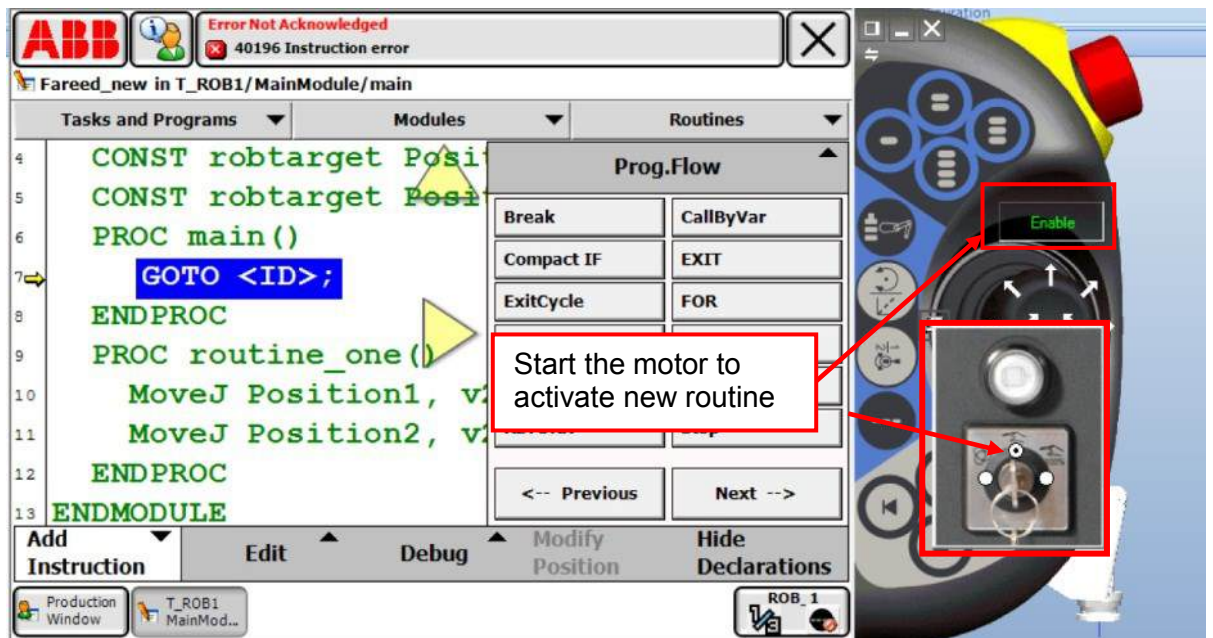

Picture 26 (robot studio screenshot)

Then we need to save the new routine to a new name.

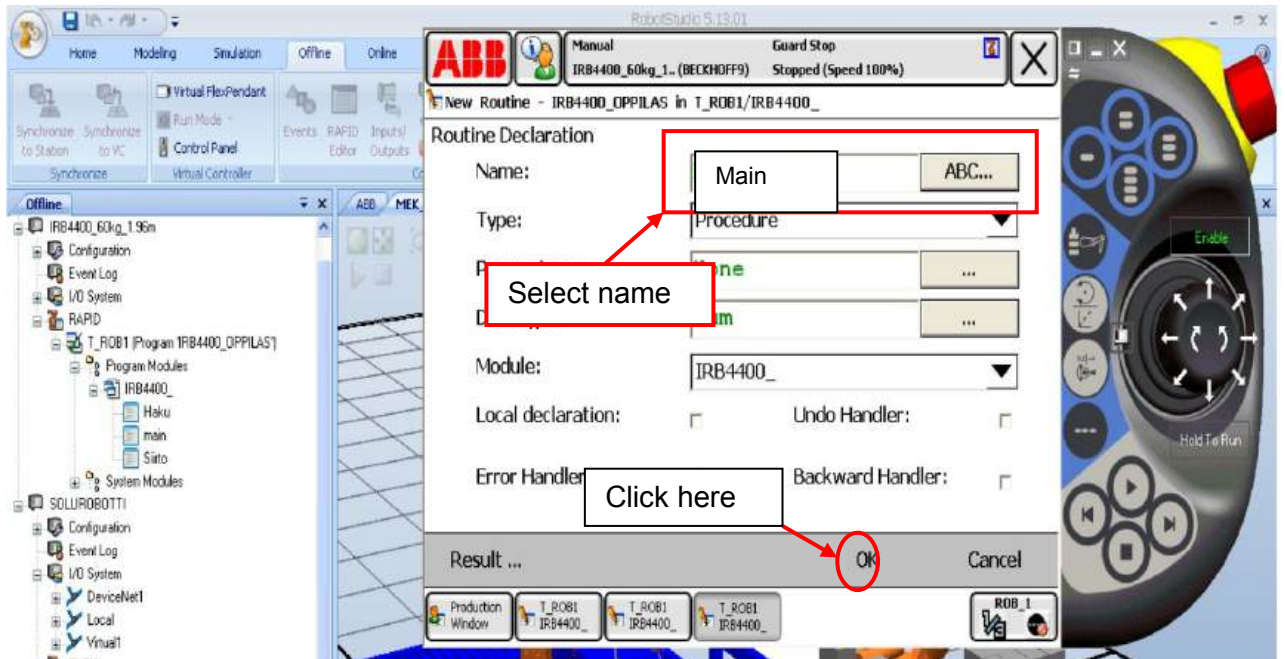

Picture 27 (robot studio screenshot)

Then it will look like this, select any routine and click **Show Routine**.

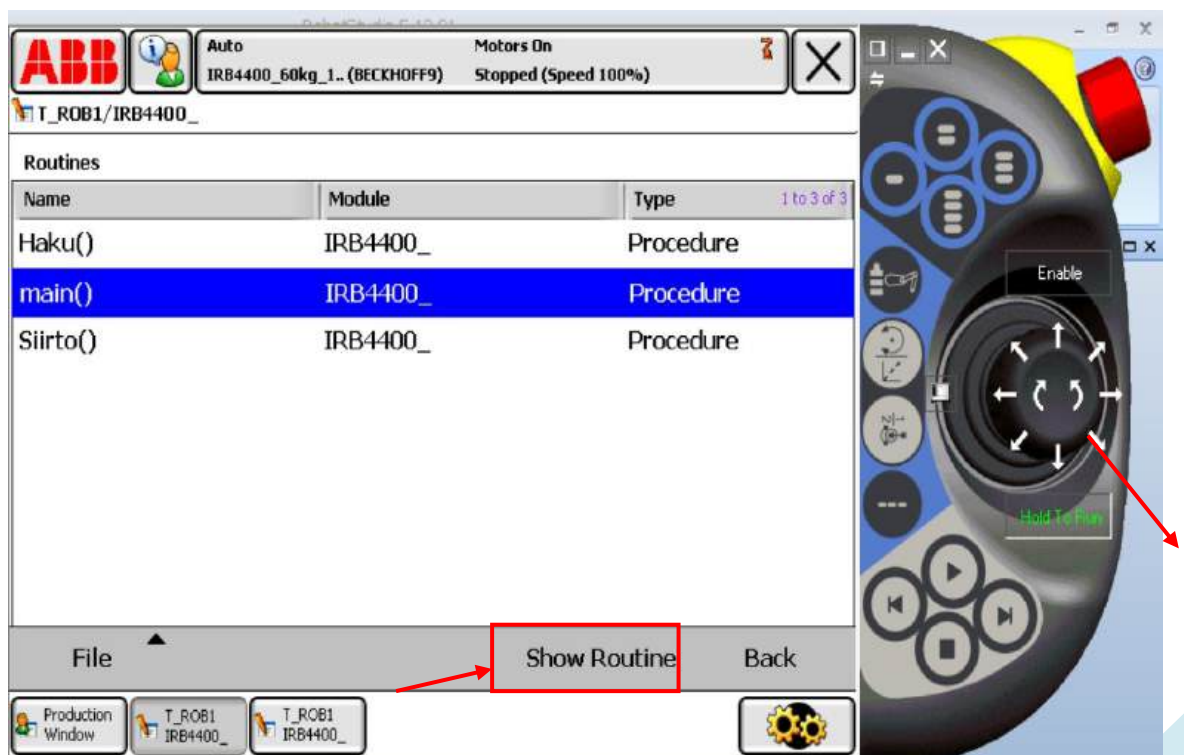

Picture 28 (robot studio screenshot)

From add instruction icon we will get the entire command menu on the right side but if we need more command we need to click next.

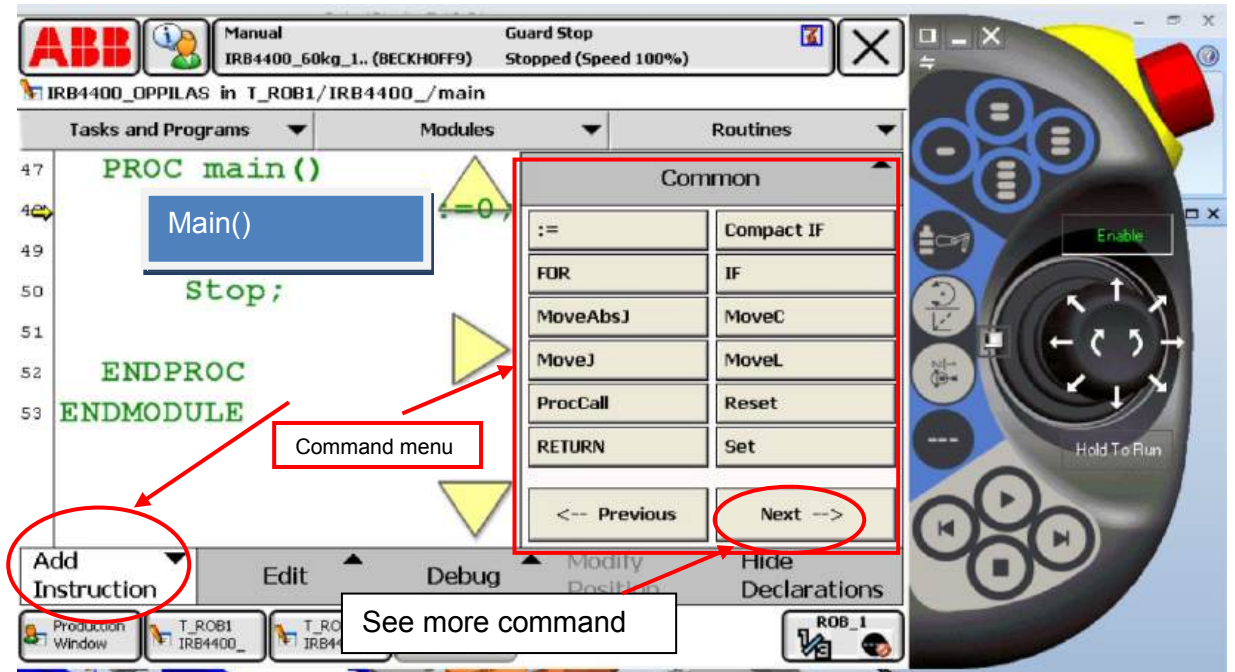

Picture 29 (robot studio screenshot)

We first move the robot coordinate of one joint then we stop to save the movement by clicking move jointJ click. Then we paint just the star (\*) and double click the star the it open new window like in picture 3 then we give name for the movement for example pist1

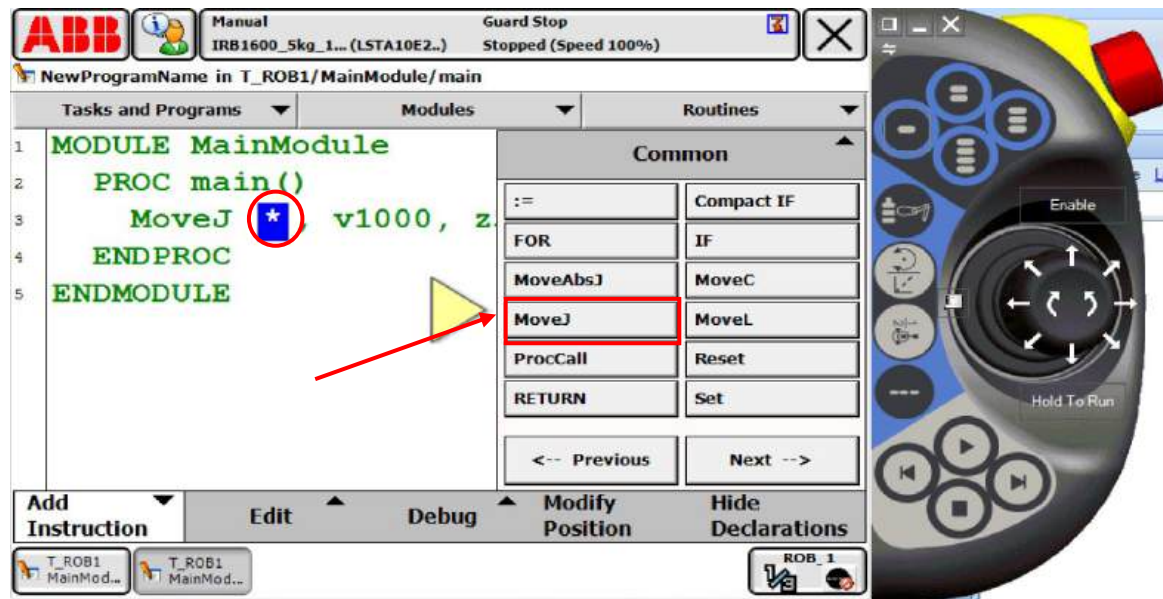

Picture 30 (robot studio screenshot)



Picture 31 (robot studio screenshot)

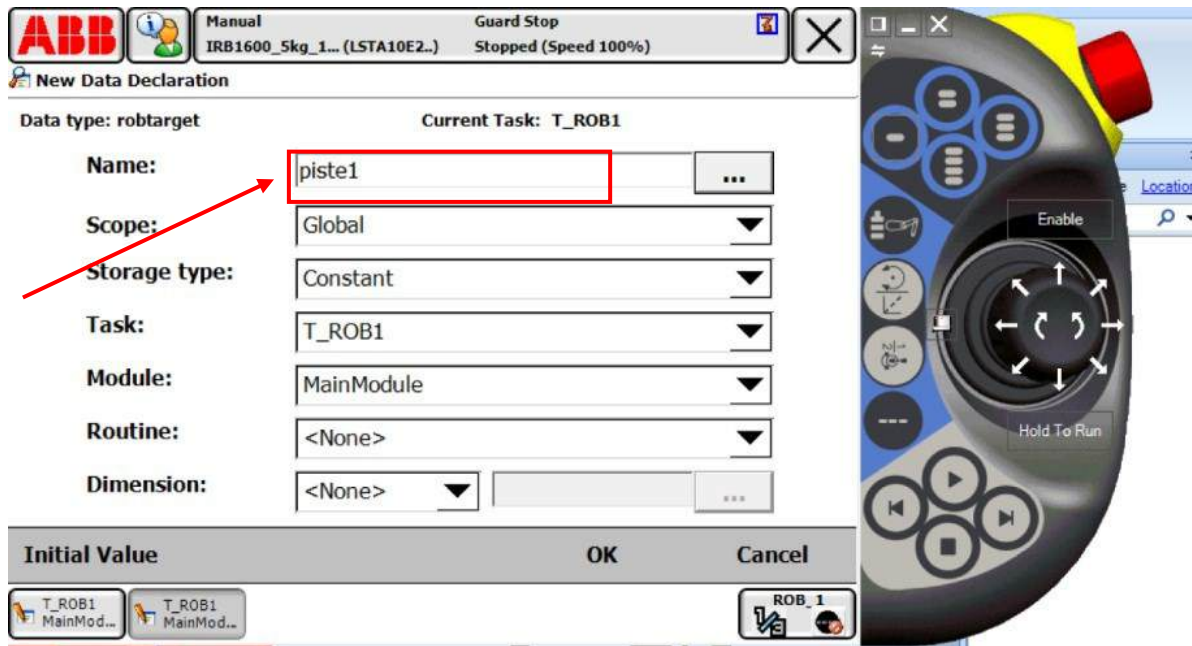

Picture 32 (robot studio screenshot)

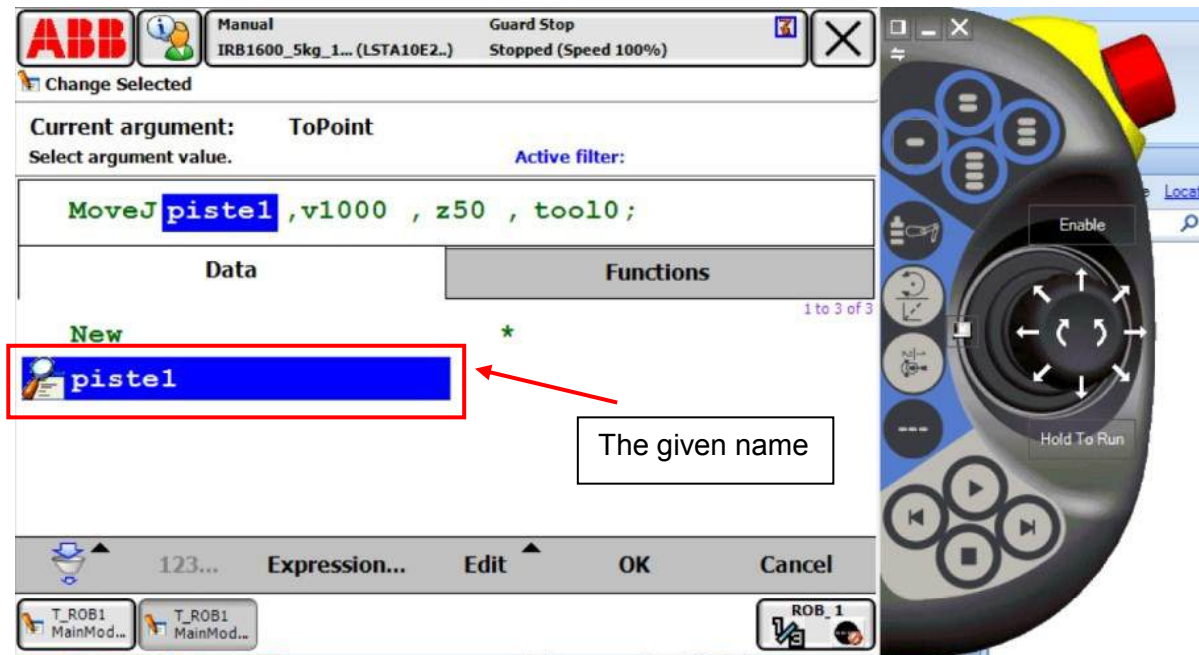

Picture 33 (robot studio screenshot)

Now we need to change the speed by clicking v1000 to choose for example to v500 from the list of speed

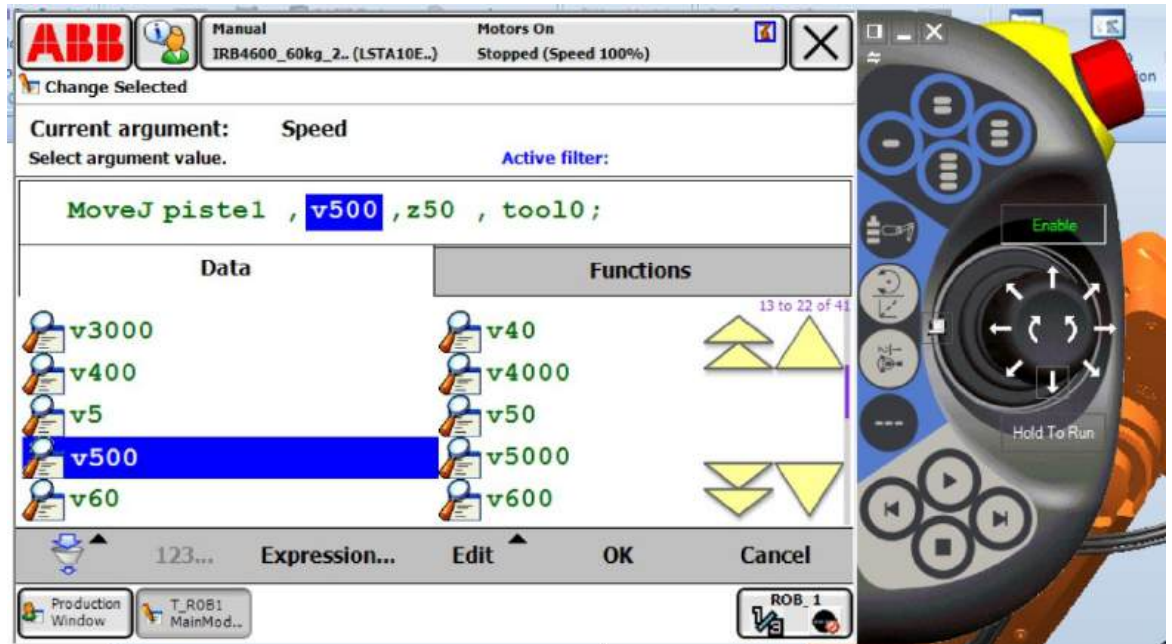

Picture 34 (robot studio screenshot)

Now we need to change the curve radius motion by clicking z50 to choose for example to z40 from the list of curve list.

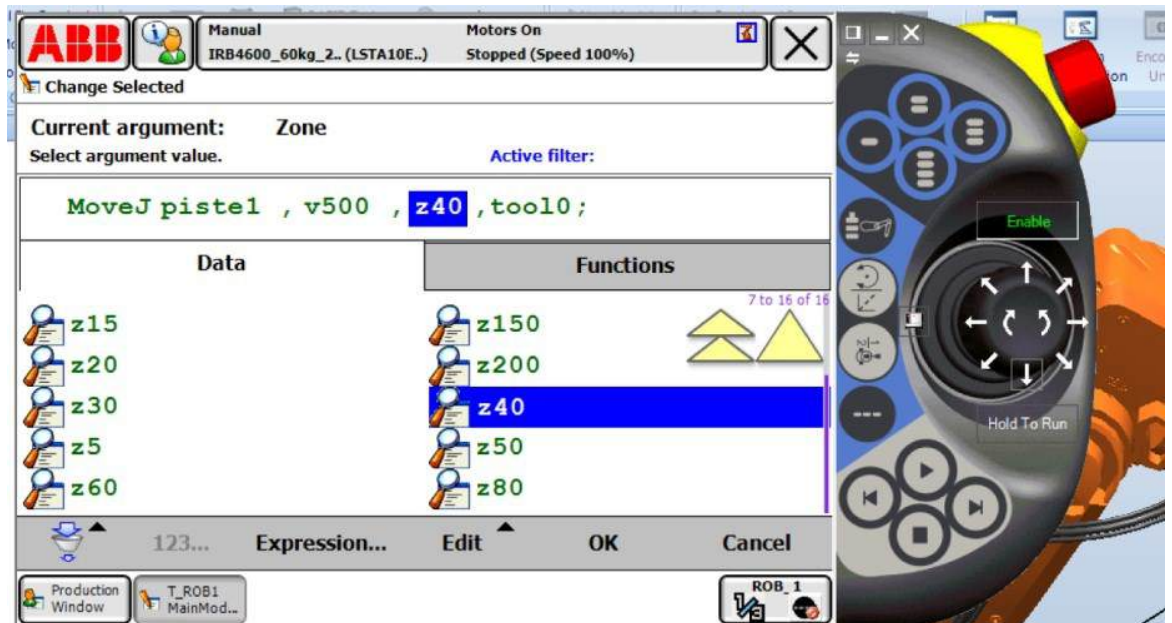

Picture 35 (robot studio screenshot)

Now we can change tool name by clicking new so new window open to rename your tool name or select tool from tool list.

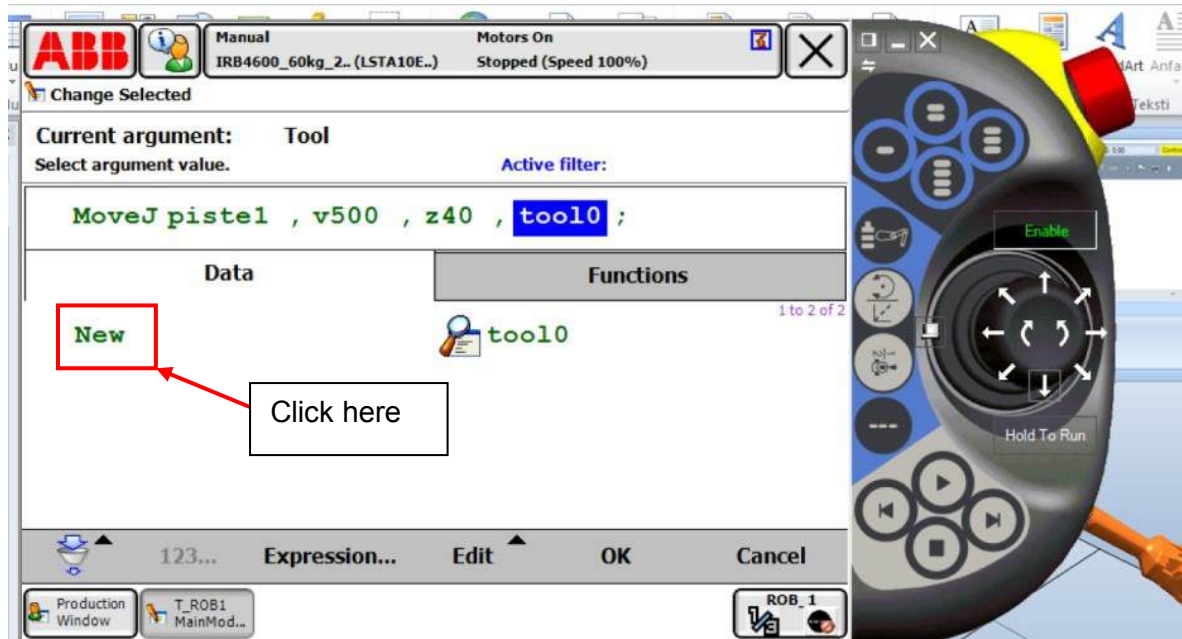

Picture 36 (robot studio screenshot)

We repeat the same step many times by using the same previous procedure .

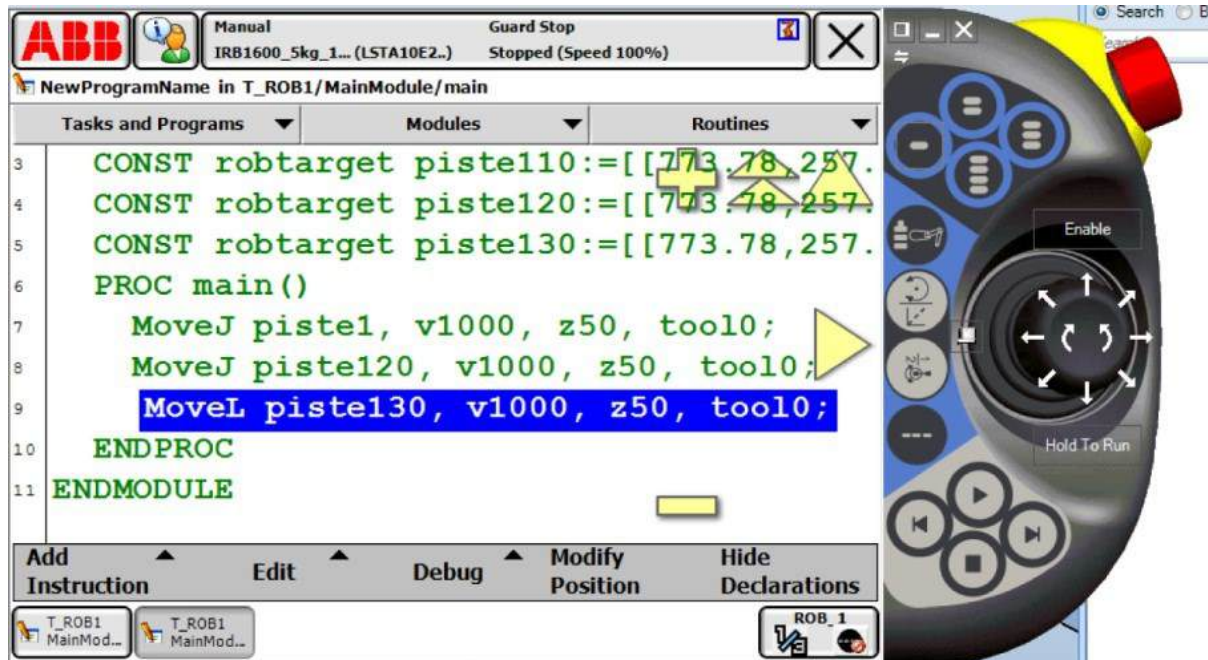

Picture 37 (robot studio screenshot)

Now we need to give command pick up and pick off the object we click first on command up then I/O

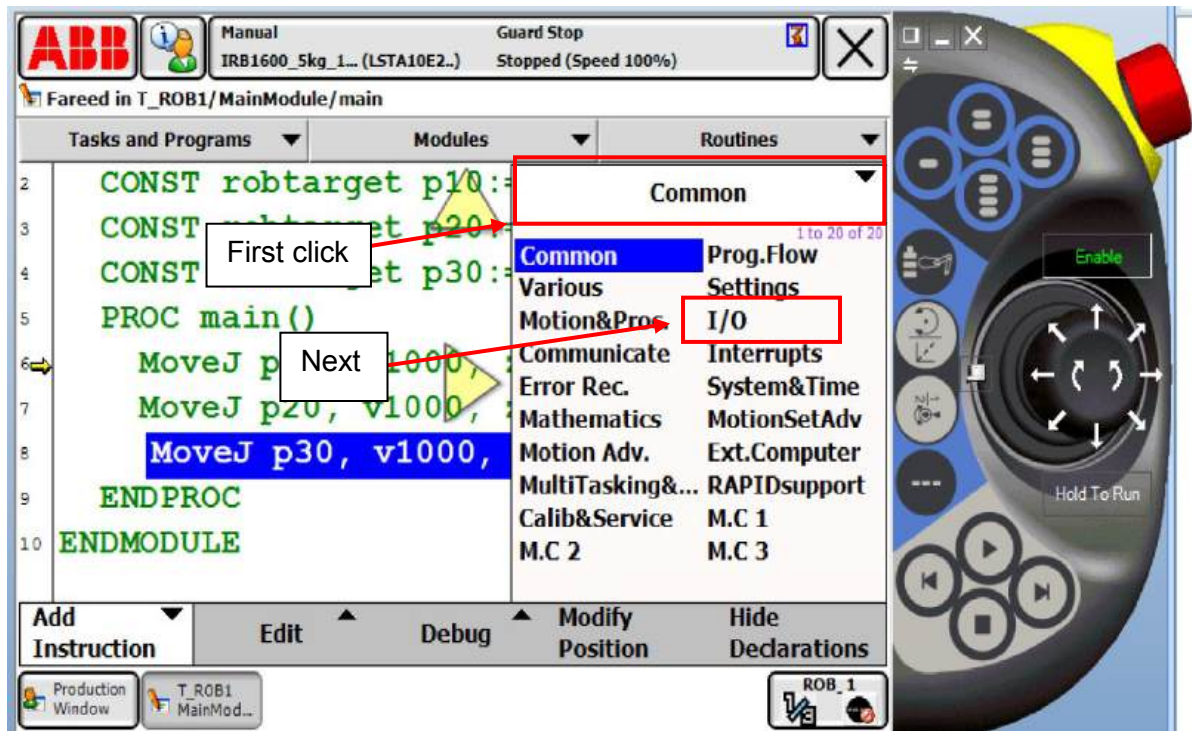

Picture 38 (robot studio screenshot)  
How to select motion and progress

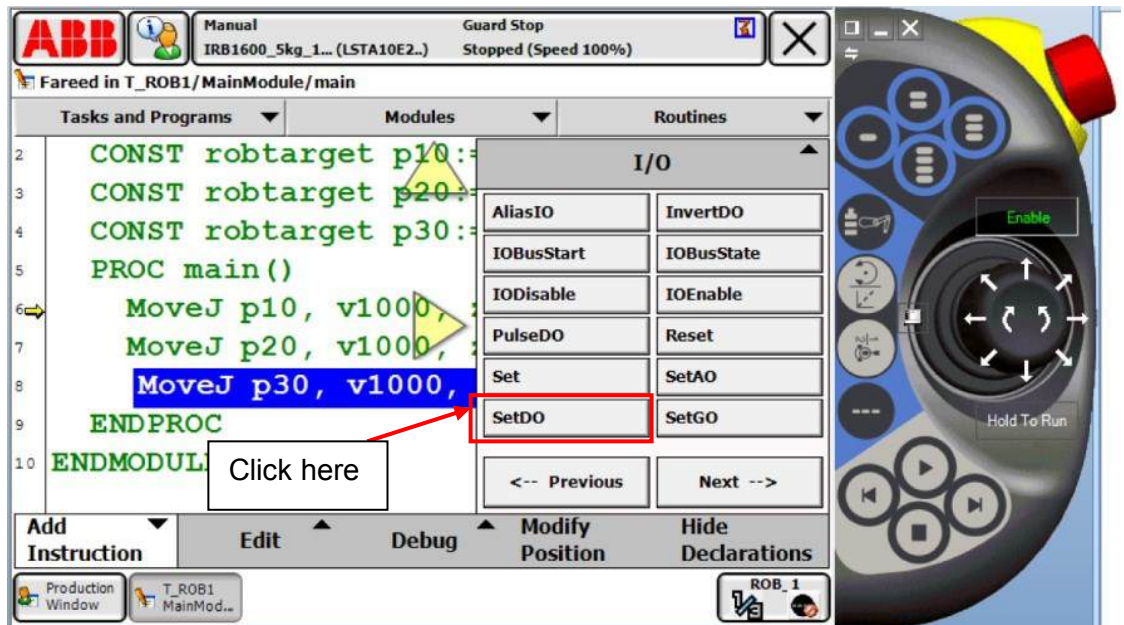

Picture 39 (robot studio screenshot)  
How to reach setDo

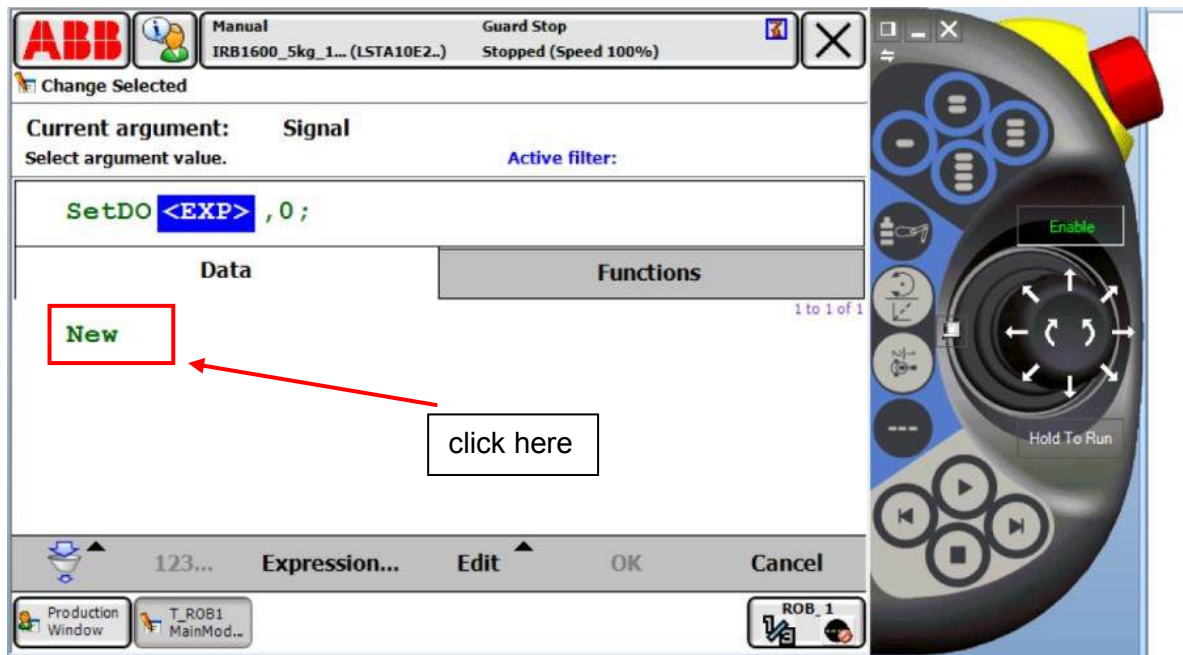

Picture 40 (robot studio screenshot)  
How to rename new

We rename it here.

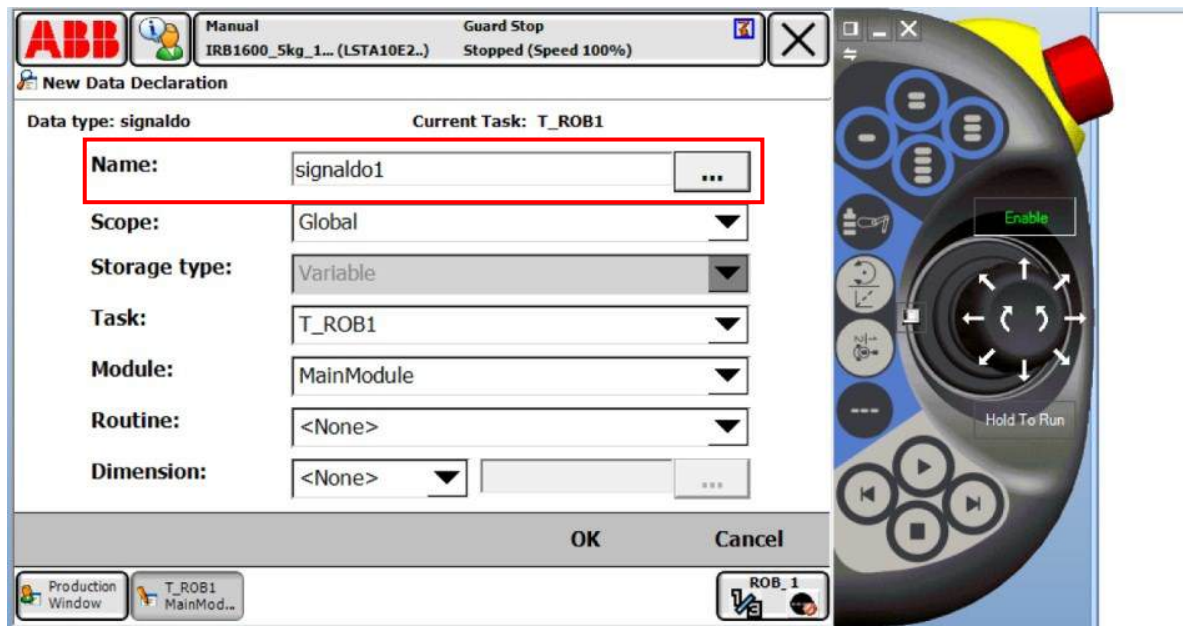

Picture 41 (robot studio screenshot)

Notice: When you select number 1 then you choose to pick up the object but when you select 0 the you choose to leave the object

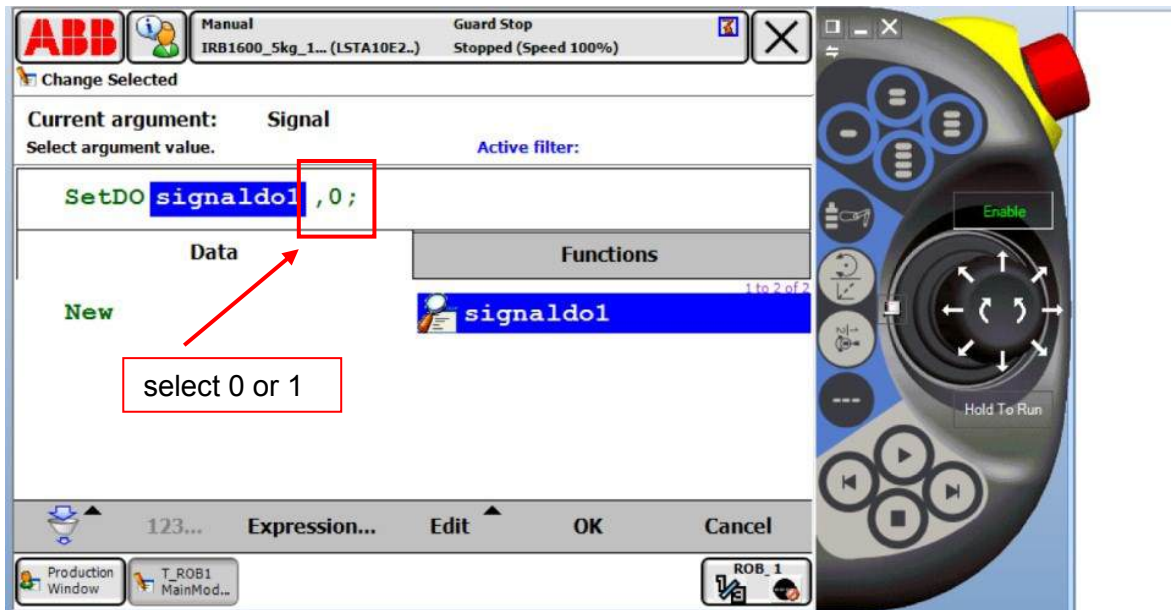

Picture 42 (robot studio screenshot)

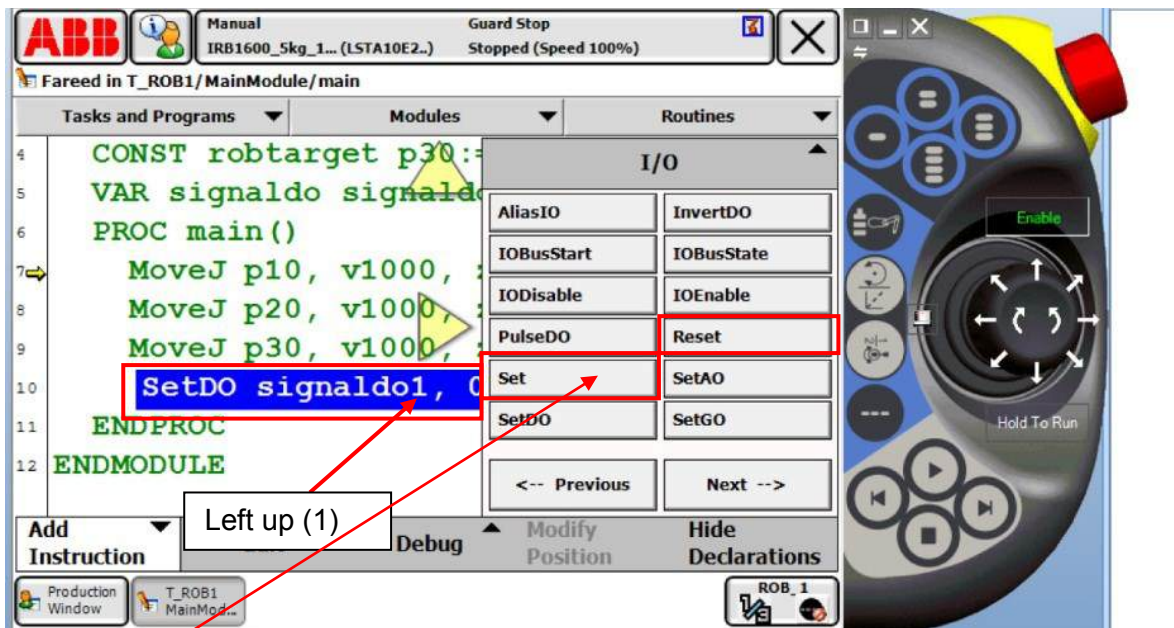

Picture 43 (robot studio screenshot)

Notice: We can also use the command set (1) and reset (0) for tool to pick up object and to leave it. The command set and reset is more simple to use for example set is to pick up and reset to leave object.

The command wait time we click on next until we get the various list of option for wait command list.

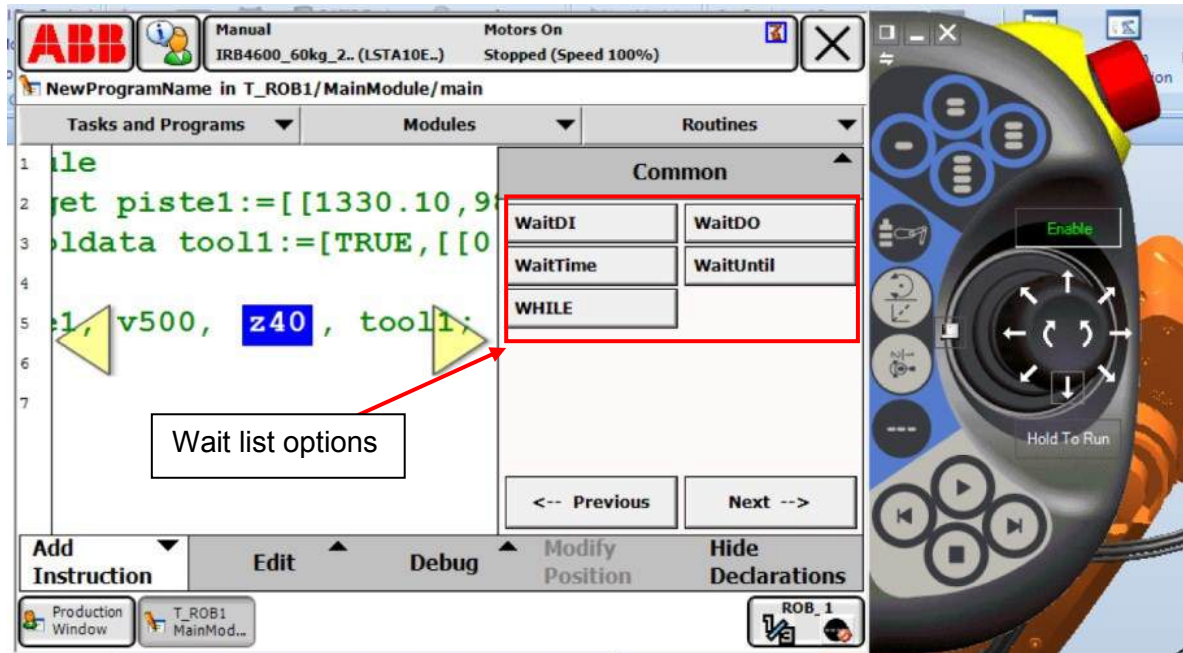

Picture 44 (robot studio screenshot)

When we click on any wait command it will open this window asking where you want to put the command line above or below the shadow line.

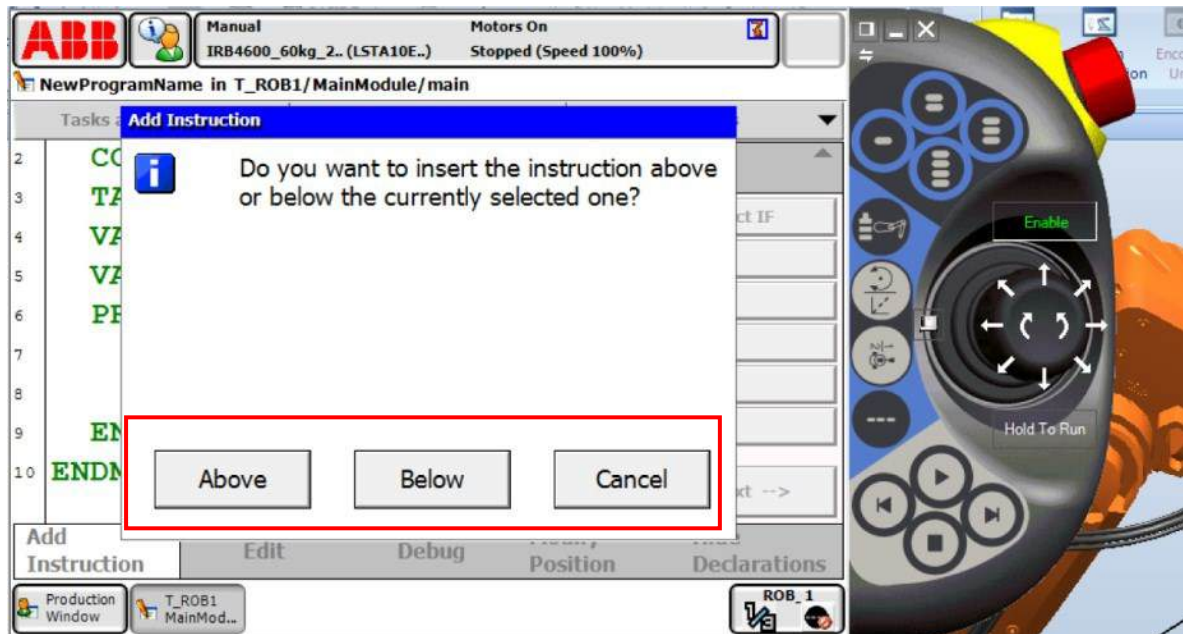

Picture 45 (robot studio screenshot)

Waiting time is chose from this window. There are several methods for defining waiting time whether by giving seconds number of value or by waiting until input or output status is changed from 0 to 1 or vice versa.

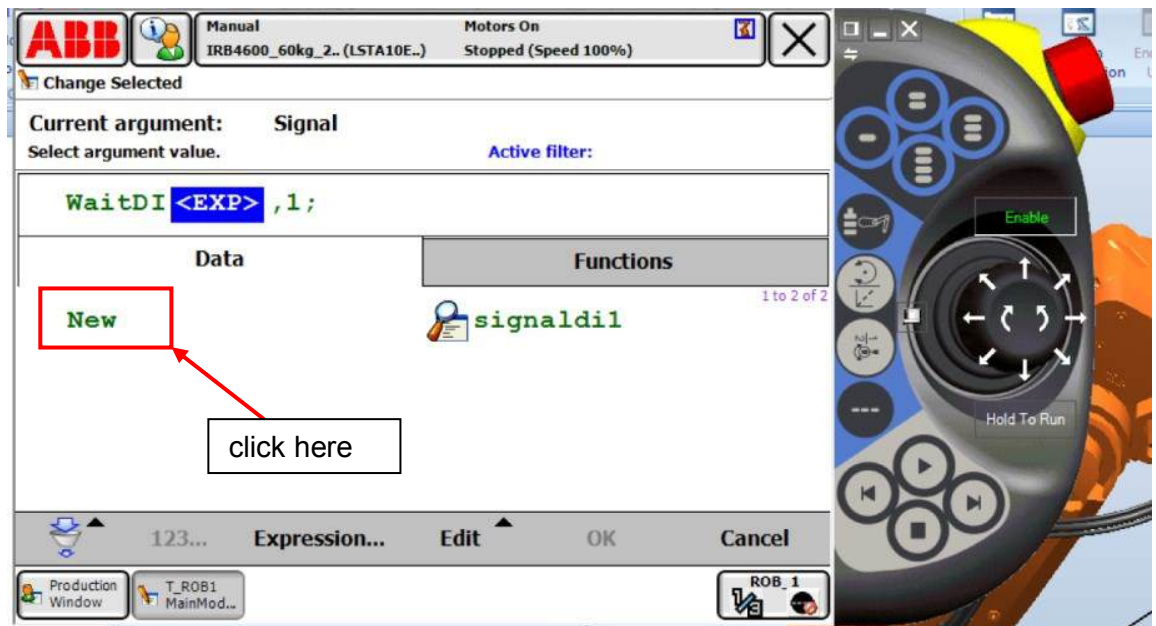

Picture 46 (robot studio screenshot)

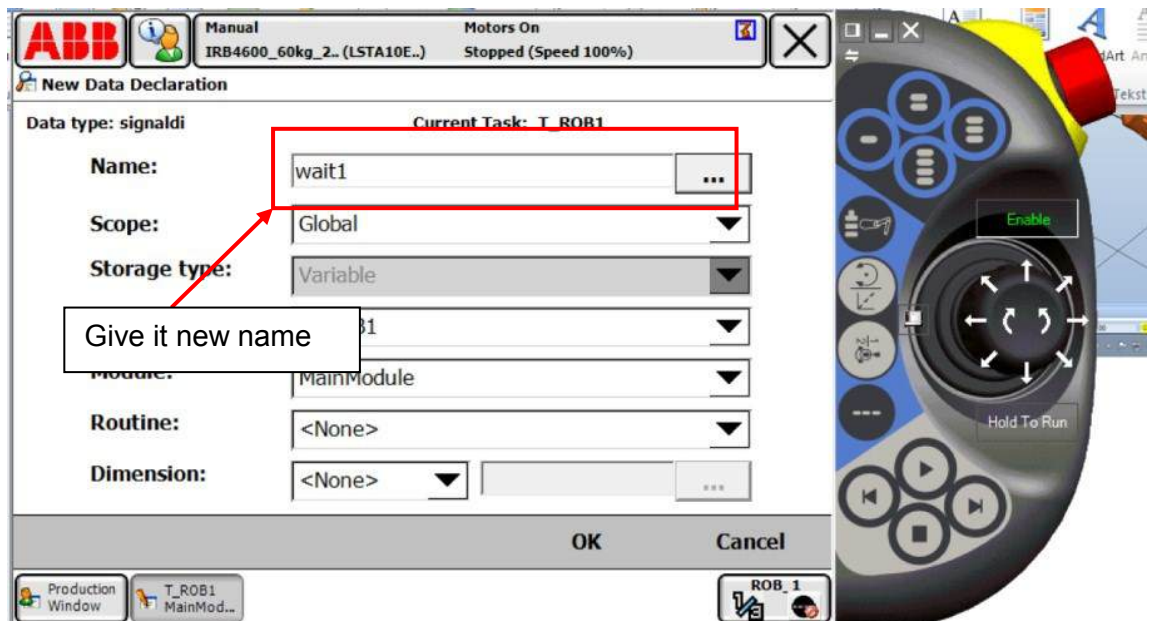

Picture 47 (robot studio screenshot)

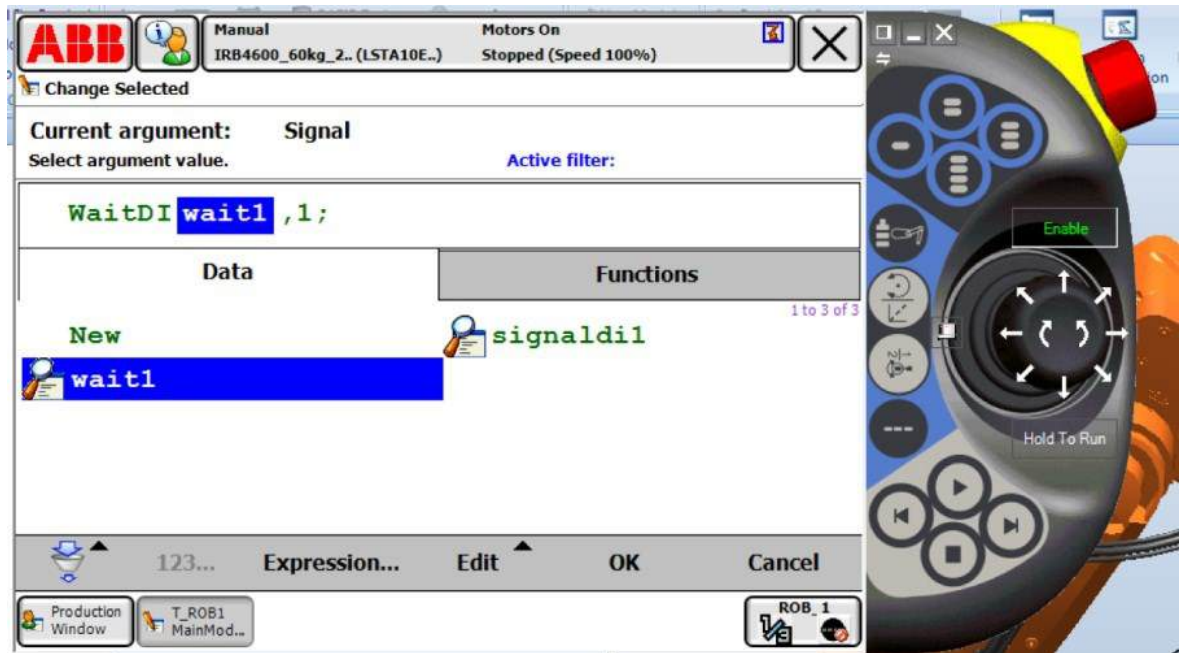

Picture 48 (robot studio screenshot)

Edit command we can use to copy and paste and some other command instruction in the following Icon.

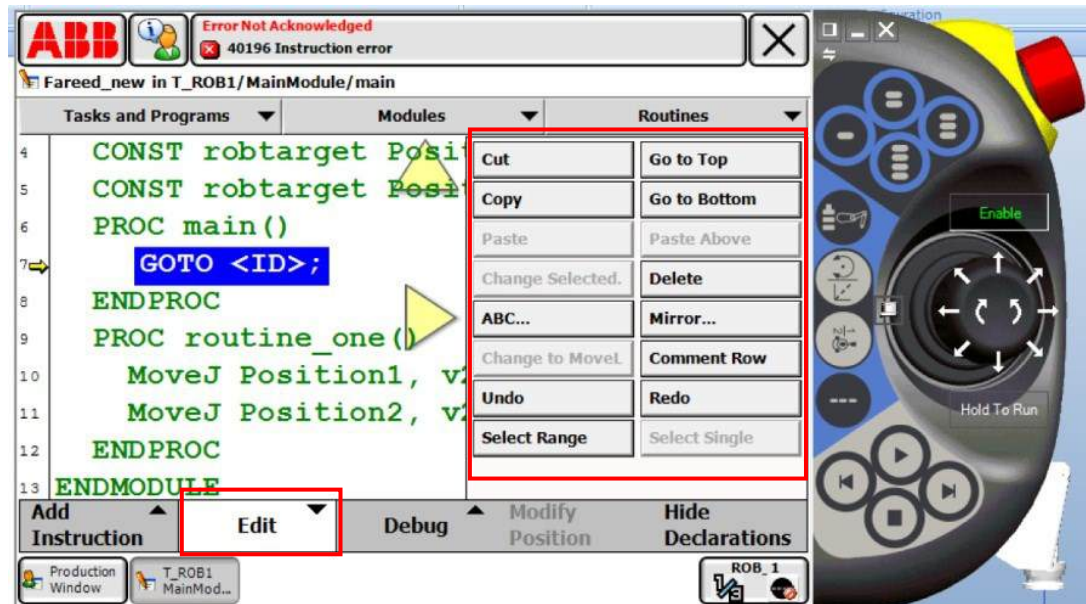

Picture 49 (robot studio screenshot)

Finally debug command for simulation and running the program.

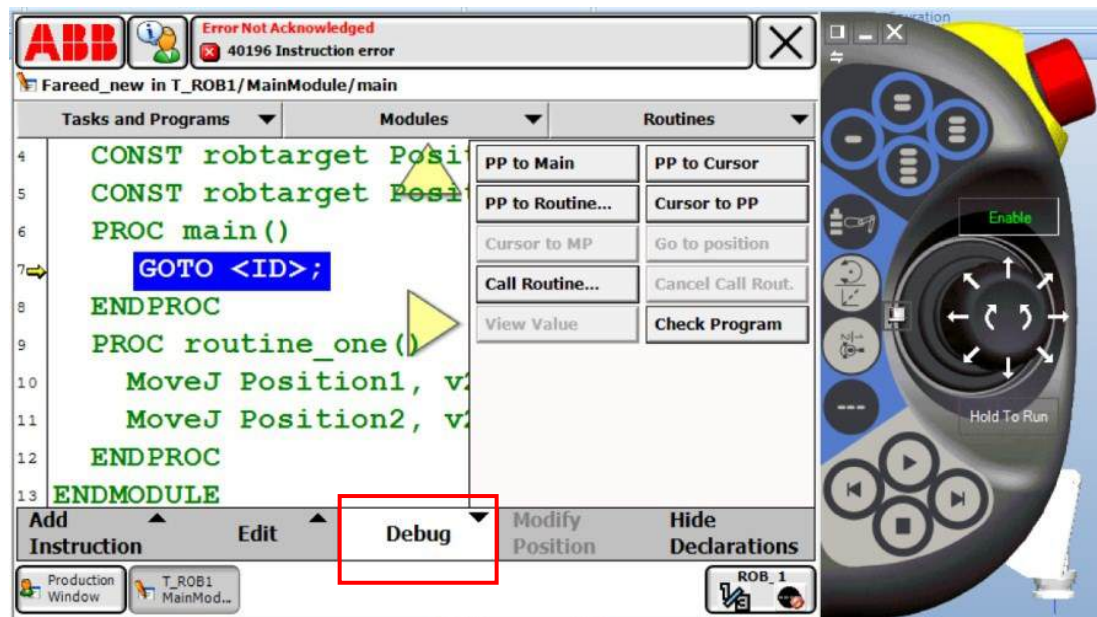

Picture 50 (robot studio screenshot)

## CONCLUSION

**The basics of robotics** are quite an extensive field and wide study, which requires both theoretical study and work experience to apply with a theoretical study. Anyone reading my thesis will find it like an introduction for robotics and the first step for beginning to understand a robot. During work experience the knowledge will increase fast by combining theoretical knowledge with the practice. In my thesis I concentrated on the beginning in the robot types and applications and tried to give the reader an idea why we need robots in our lives. Then about robot technology and the structure of a robot were also introduced by writing about the mechanical parts and electrical parts that we use in building a robot and what is the purpose of each part, besides providing pictures of robot parts because pictures can give the reader a better idea on the subject without to begin to imagine something, which is completely wrong. In the end I would say that robotics study is challenging and complicated and I recommend anyone to begin with simple stuff by playing with some sensors and actuators and try to create logic system and gradually the knowledge will grow with more practice.

## Appendices:

### Books:

Matter	The author	Year	Title	Puplication place
Robot	JOHN J. CRAIG	2005	Introduction for robotics	USA Stanford
Matrix and vectors			Linear algebra	
Robot	Bruno Siciliano, Oussama Khatib	2008	Springer Handbook of robotics	USA Stanford
Robot continents	Paul E. Sandin	2003	Robot Mechanisms and Mechanical Devices	The McGraw-Hill Companies USA
Mechatronics	Robert H Bishop	2006	Mechatronics An Introduction	University of Texas USA

### Lectures:

Automation Servo motor drive	Teijo lahtinen	2010	Lectures Basic of automation Servo motor	Lahti , Finland
Pneumatic	Arto kettunen	2010 2011	Lectures Pneumatic, logic system	Lahti , Finland
Robotic perusteet	Matti pikälä	2011	Lecture of robotic	Lahti , Finland
Matrix and vectors	Tapani Kuusi	2010	Lecture of matrix and vectors	Lahti , Finland

### websites

[http://en.wikipedia.org/wiki/Industrial\\_robot](http://en.wikipedia.org/wiki/Industrial_robot)